

# Quick Start Guide for 3DVA120/3DVA120-H Meters

## Hardware Installation

### Meter Dimensions and Cut-out

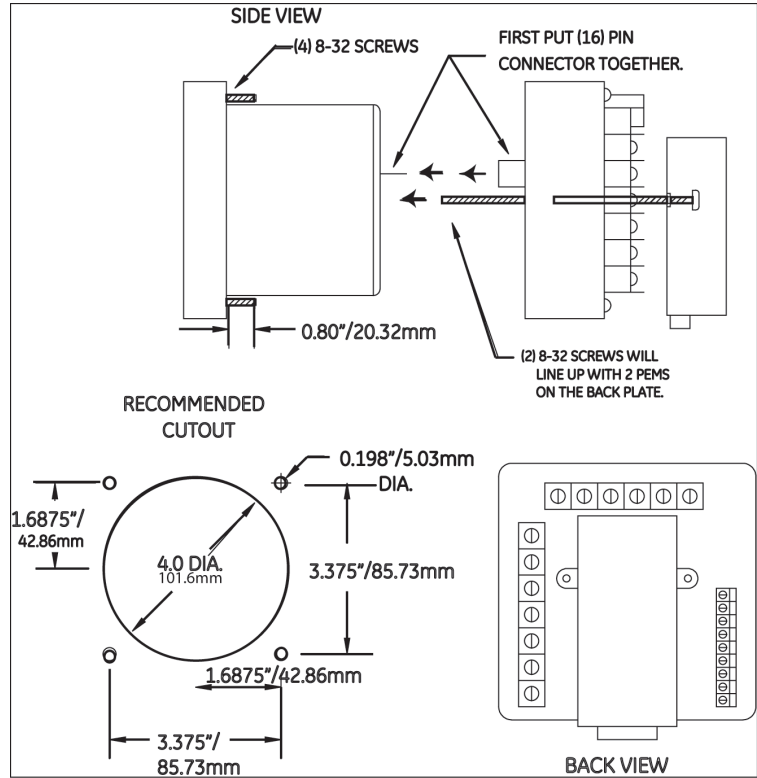
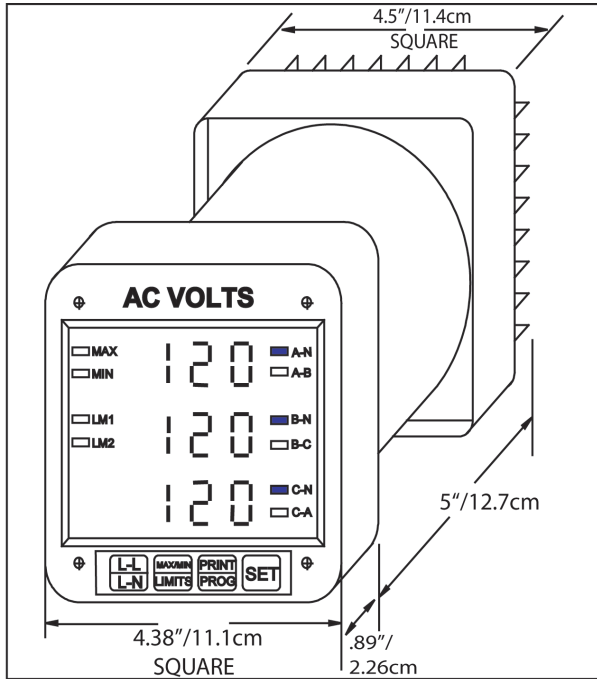

## Electrical Installation

(Refer to the meter's User manual on the enclosed CD for additional wiring diagrams.)

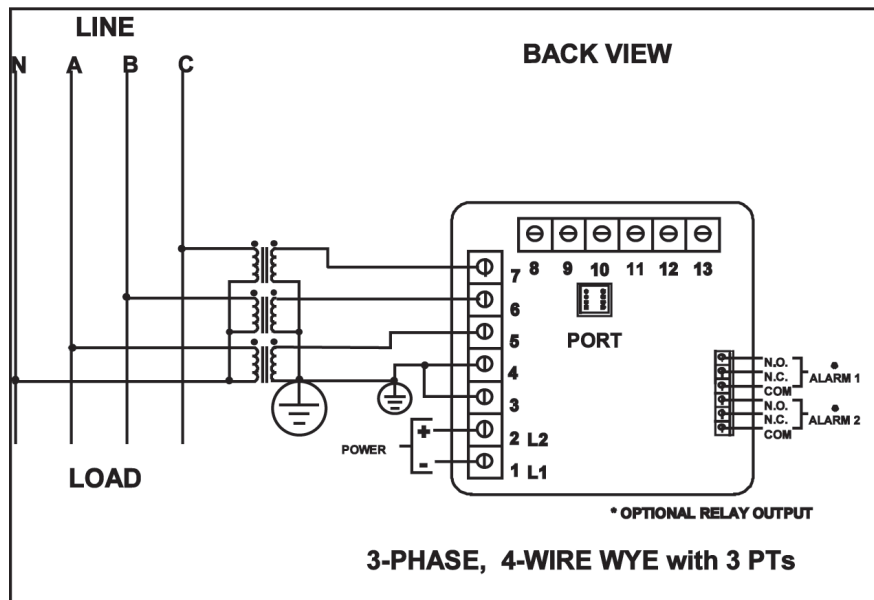

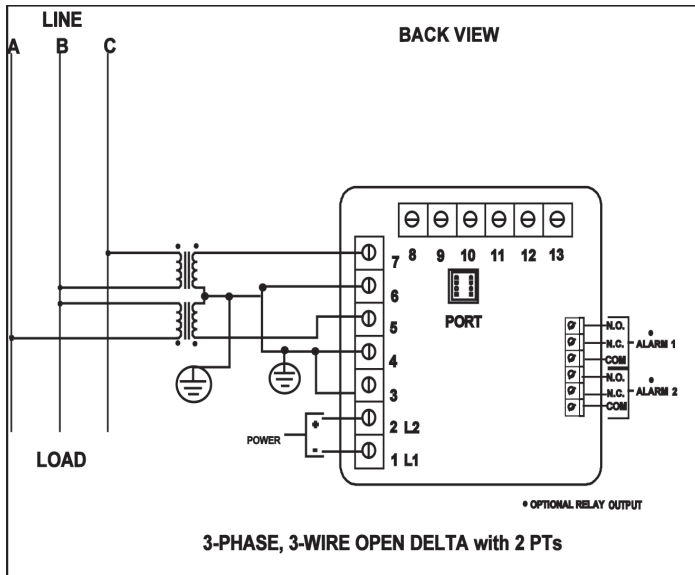

## Programming the Meter

- Basic programming information is given here. For step-by-step instructions refer to the meter's User manual, on the enclosed CD.
- Programming tasks are divided into 9 Groups that contain programming Functions. Use the meter buttons to access the Groups/Functions and program the meter.
- Programmable Function values are always four-digit numeric fields. For example, to enter the number 25, you must enter 0025.

### Enter Programming Mode:

1. Press and hold PRINT/PROG until 3 appears in the bottom display.
2. Press SET to multiply the 3 to 333.
3. Digits begin scrolling in the upper display. Press SET each time 5 appears, until the bottom display reads 555 (this is the meter's password).
4. PPP and then 0 appear in the upper display: the meter is now in programming mode for Group 0.

### Exit Programming Mode: IMPORTANT! You MUST exit Programming Mode to store any changes.

NOTE: The steps to exit Programming Mode depend on your current stage. If you are located at Function level begin at Step 1; if you are located at Group level, begin at Step 3.

1. Press L-N/L-L until the Group number in the upper display is followed by E (Exit).
2. Press PRINT/PROG to return to Group level.
3. Press L-N/L-L until E appears in the upper display.
4. Press PRINT/PROG to exit Programming Mode.

### Programming Voltage Full Scale Settings

1. Enter programming mode (see instructions above).
2. Press L-N/L-L until 1 appears in the upper display.
3. Press PRINT/PROG to activate GROUP 1:
  - 10 appears in the upper display; the current value appears in the lower display, and the middle display contains a vertical line indicating Scale factor: an UP position represents Kilovolts; a DOWN position represents Volts. See the example figure on the right.
4. Press PRINT/PROG to begin data entry: the lower display is replaced with a single dash.
5. Press MAX/MIN/LIMITS to set the Scale factor by moving the vertical line UP (for Kilovolts) or DOWN (for Volts).
6. Press PRINT/PROG to store the value. A decimal point appears in the lower display.
7. Press MAX/MIN/LIMITS to move the decimal point, then press PRINT/PROG to store the setting.
 

NOTE: If the decimal point is already where you want it, press PRINT/PROG to continue.
8. The middle display contains the present Full Scale for Volts and four dashes appear in the lower display for data entry. Enter the four digit Full Scale value you want by pressing MAX/MIN/LIMITS to increase the digit's value, and then pressing PRINT/PROG to store each digit. Repeat until all four digits are entered.
9. The lower display contains the new Full Scale setting; the middle display indicates the Scale Factor; the Group and Function number appear in the upper display. **IMPORTANT! When you are done, follow the Exiting procedure described above.**

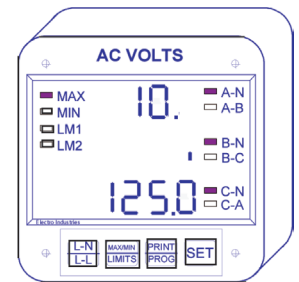

NOTE: Refer to your meter's User manual on the enclosed CD for step-by-step instructions for additional programming tasks.

### Electro Industries/GaugeTech

1800 Shames Drive Westbury, New York 11590

Tel: 516-334-0870

FAX: 516-338-4741

www.electroind.com

E104781 V.1.01 041510