

Nexus[®] 1252

For Smart Grid and Substation Automation

Accu-Measure[™]
Technology

Advanced Performance Smart Power Meter

and Substation Data Acquisition Node

Auto-Calibrating
Metrology

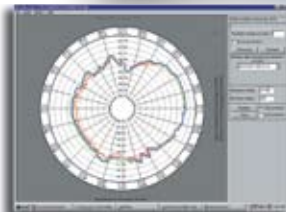

0.06% Billing Grade
Power Metering

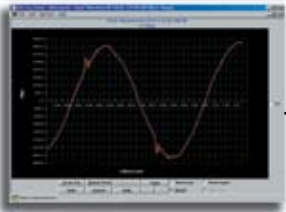

Performance Power
Quality Monitoring



XML Web Server
with Email Alarms

New USB Front Panel
Download Port

- Billing Grade Revenue Meter
- RTU with I/O & Control
- Power Quality Recorder
- Onboard Ethernet Connectivity
- DNP 3.0 Level 2 Plus
- Extensive Communication Capabilities
- Smart Grid and Automation Solutions

www.electroind.com



Electro Industries/GaugeTech

The Leader in Power Monitoring and Smart Grid Solutions



ELECTRICAL & ELECTRONIC
MEASURING & TEST EQUIP.
64JA

Smart Grid and automated data collection solutions are the backbone of a modern power distribution system. From the residential metering point to the sophisticated transmission substation automation solutions, accurate and reliable data collection is critical to success. The advanced monitoring features of the Nexus® 1252 provide the total picture of power usage and power quality for any metered point within a power distribution network, allowing power related decisions to be made quickly and effectively. With EIG's exclusive Total Web Solutions, you can monitor your Nexus® 1252 anytime and from anywhere via the Internet and receive critical alarms via email when action is required.

Technology Designed For Utilities, Industrial Users and Critical Power Applications

FOR ENERGY PROVIDERS

(Utilities, Municipals, ESPs, Independents, etc.)

- Improve Substation Automation Solutions
- Increase Power Distribution Reliability
- Record Faults/Time Protective Equipment
- Monitor Reliability of Breakers and Relays
- Shed or Shift Loads Quickly
- Identify and Manage Peak Demand
- Heighten Response Time to PQ Events
- Enhance Levels of Communication and Data Transmission
- Provide Real Time Data on the Web

FOR ENERGY CONSUMERS

(Industrial, Commercial, Government, Etc.)

- Real Time PQ Monitoring and Analysis
- Efficiently Control/Manage Energy Consumption
- Reduce Costs/Conserve Energy
- Improve Operational Efficiencies
- Increase Productivity/Reduce Downtime
- Optimize Loads/Extend Equipment Life
- Identify and Respond to PQ Events Quickly
- Avoid High Utility Penalties for Exceeding Usage
- View Energy Usage and Power Quality through the Web

Obtain High-End Power Quality and Accurate Billing Measurements

High-performance energy usage and power quality data is always available at your fingertips with the Nexus® 1252. The meter provides you with the necessary power system assessment information in real time. The Nexus® 1252 provides advanced power disturbance recording including EN50160/EN61000-4-15 Flicker Analysis and AI-based PQ reporting. Use Nexus®' precision accuracy for primary metering or submetering for checking on an installed utility meter.

Expandable I/O and Trending Customize Nexus® For Every Application



Nexus® offers virtually unlimited I/O capability in conjunction with all metering functions. Expandable I/Os enable the meter to be used for all metering and data-gathering applications. Nexus®' modular plug-in design allows you to add analog and digital I/Os to specifically meet your application. With this advanced I/O capability, you can use Nexus® to replace RTUs and PLCs for energy management and substation automation solutions. With Nexus®, you can monitor system apparatus reliability such as transformers, circuit breakers, or other critical equipment.



Accu-Measure™ Technology

Multi-Part Approach To Precision In Accuracy

The Nexus® 1252 is the first meter of its kind to utilize EIG's patented Accu-measure™ Technology. Accu-measure™ is a technique based on a multi-part approach that allows a field-mounted metering device to achieve laboratory grade accuracy.

DUAL HIGH POWERED 16 BIT A/D CONVERTERS

Dual 16 Bit A/D converters provide supreme sampling accuracy and resolution.

DUAL INTERNAL REFERENCES STABLE TO 5 PPM/CELSIUS

The unit auto-adjusts to dual internal references stable to 5 parts per million. These references insure that the monitoring equipment maintains its calibration.

AUTO-CALIBRATION WITH TEMPERATURE COMPENSATION

The Nexus® uses an auto-calibration technique that re-calibrates the unit on the fly when the temperature changes more than 5 degrees Celsius, monitoring for accuracy over temperature.

PRECISION ACCURACY SPECIFICATIONS

With Accu-measure™, this unit meets ANSI C-12 0.2% accuracy specifications watt-hour accuracy.

Revenue Metering Features

TRANSFORMER LOSS AND LINE LOSS COMPENSATION

The unit compensates for transformer and line losses. Power reading compensation is conducted for both iron and copper losses.

CT AND PT COMPENSATION

The Nexus® unit compensates for errors in current transformers and potential transformers.

- Voltage Compensation
- Multipoint Current Compensation

- Multipoint Phase Angle Compensation
- Better than 0.01% Resolution

TIME OF USE CAPABILITY

Nexus® offers comprehensive time of use capability. Standard features include:

- Bidirectional Consumption and Demand Quantities
- 20 Year Calendar
- 4 Seasons/Yr
- 12 Holidays/Yr
- 4 TOU Schedules/Season
- Prior Month, Prior Season Storage
- Present Month, Present Season Storage

MAX/MIN INTEGRATION AND RECORDING

The unit offers time stamped max and min values for almost all measured readings. A time stamp is associated with each max and min. KW readings are integrated using:

- Block (Fixed) Window
- Thermal Window
- Rolling (Sliding) Window
- Predictive Window. Any integration period is allowed. The default period is 15 minutes.

COINCIDENTAL READINGS

When logging max Watt readings, the coincidental VARs at the time of the max are also recorded. You can determine the number of capacitors needed, identify peak inefficiencies and resolve many other issues.

PASSWORD PROTECTION PREVENTS UNAUTHORIZED TAMPERING

Two 10-character, alphanumeric passwords protect the unit from unauthorized tampering. The first level password is a general password allowing a user to view readings, but not change them. The second level password allows the user to change and re-program the unit.

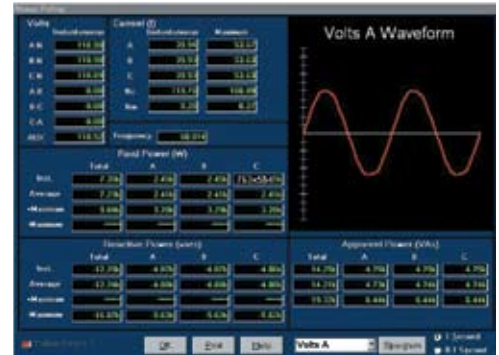

Real Time Readings & Waveform Display



4 Quadrant Energy and Demand

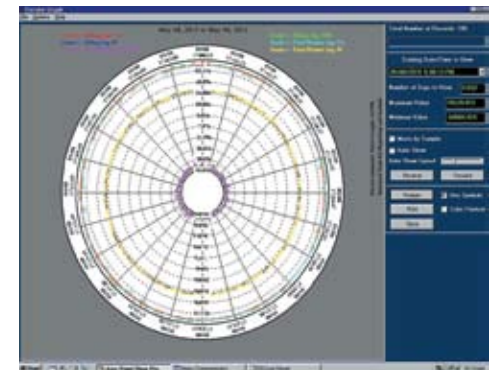

Historical Trends for Any Parameter

LOAD AGGREGATION/UNIVERSAL METERING

Using the status inputs, Nexus® has the ability to count pulses and aggregate different loads providing a total picture of the load and its component parts. The pulse inputs can be used to accumulate and aggregate all other utility values such as water and gas.

- 8 pulse inputs standard
- 4 aggregators
- 32 additional external pulse inputs



16 BIT WAVEFORM EVENT AND FAULT RECORDER

The unit records up to 512 samples per cycle for a Power Quality event. Voltages and currents are recorded with pre- and post-event analysis. Fault recording offers 8x full scale capture capability on current. All voltage and current readings are recorded using a 16 bit A/D converter providing precise waveform resolution. Both hardware and software triggers are available to activate a waveform recording, which can be used for power quality surveys, fault analysis, breaker timing, etc.

MEASURE AND RECORD HARMONIC MAGNITUDES TO THE 255TH ORDER

The unit measures harmonic magnitudes up to the 255th order for each voltage and current channel. Real Time Harmonics are resolved to the 128th order. Percent THD and K-Factor are also calculated. This high performance harmonic analysis allows users to conduct power quality analysis at the high end of the harmonic spectrum.

SUBCYCLE TRANSIENT RECORDER

The unit records subcycle transients on voltage and current readings. It monitors switching noise from capacitors, static transfer switches, SCRs and many other "power quality harmful" devices. Transients are often the cause of intermittent and expensive periods of downtime. Without Nexus, solving these problems is often impossible.

STATUS INPUT TRIGGERS

The unit records the waveform at the time of the status change. The input change and waveform recording are time stamped to a 1msec resolution. Up to 8 inputs can be plotted on the waveform. This enables a user to time the reliability of relays and circuit breakers.

ADDITIONAL INPUTS

Nexus® offers inputs for Neutral to Ground Voltage measurements. This allows you to analyze rising ground potential which often damages electrical equipment. The unit also calculates and measures the neutral current.

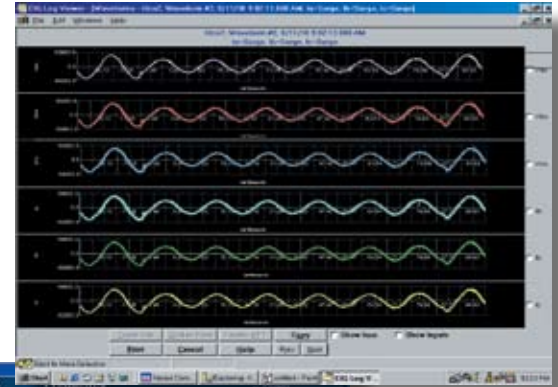

High Resolution Waveform Recording

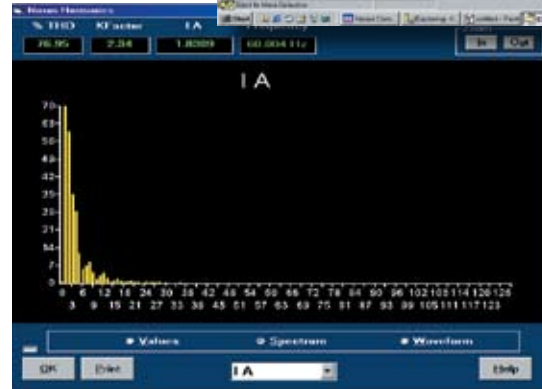

128th Order Real Time Harmonic Spectrum

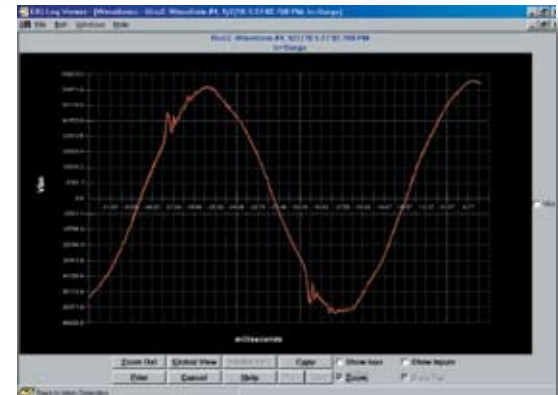

16 Bit Waveform Resolution



ITIC/CBEMA Plotting showing damaging Power Quality events.

INDEPENDENT ITIC/CBEMA LOG PLOTTING

The Nexus® stores an independent ITIC/ CBEMA Log for magnitude and duration of voltage events. With this log, the user can quickly view total surges, total sags and average duration without having to retrieve waveform information.

PHASOR ANALYSIS

The monitor reads a phase angle analysis between the voltage and current channels, allowing for efficiency and system-integrity analysis.



Phasor Analysis

EN50160/EN61000-4-15 FLICKER AND COMPLIANCE MONITORING (V-2 ONLY)

It is important to maintain a source of high quality power to insure efficient operations. One particular source of disturbance that can have very negative effects is Flicker. This consists of low frequency to intermittent line disturbances on the power line. Aside from effects on equipment, disturbances of this type can have negative effects on people.

One particular example of this is the flickering of light sources that can affect humans in different ways, depending on the severity.

The Nexus® 1252 with V-Switch 2 complies fully with the Flicker requirements of EN50160 /EN61000-4-15 and includes:

- Flicker Evaluation-Instantaneous readings suitable for on line monitoring; Short Term Readings (PST - 10 Min) - logging and monitoring; Long Term Readings (PLT - 4 hour) - logging and monitoring
- Polling Pinst, Pst, Pst Max, Pst Min, Plt, Plt Max, Plt Min values
- Log Viewer (View graphed values Pst and Plt for Va, Vb and Vc or displayed values including Max and Min.)

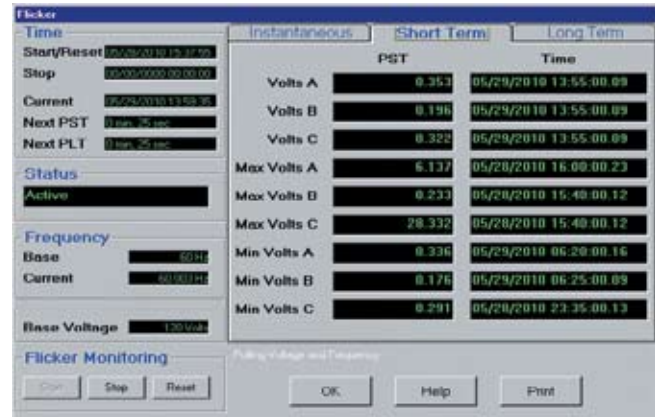

AIREPORTS EXT – PQ ANALYSIS

AiReports EXT provides automated analysis and reports for abnormal events.

- Uses Artificial Intelligence
- Evaluates All Data from Nexus® Meters
- Rates Events for Severity
- Identifies Probable Causes
- Identifies Possible Impact
- Recommends Corrective Actions or Solutions
- Prepares & Formats Reports of All Power Quality Events
- PQDIF File Format Converter allows Nexus® data to be read by standard EPRI Power Quality viewing software.
- COMTRADE File Converter changes fault records to standard fault analysis file formats.

Measure amplitudes and timing with millisecond resolution. See system reliability events that lasted for several seconds.



INTERHARMONIC ANALYSIS

The Nexus® 1252 provides users with the ability to view Interharmonics, the discrete frequencies that lie between the harmonics of the power frequency voltage and current. Frequencies can now be observed which are not an integer multiple of the fundamental and can appear as discrete frequencies or as a wide-band spectrum.

The user can set a starting point anywhere in the waveform, assuming that there are enough sample points available after the starting point. If there are not enough points in this waveform capture, the software will check the next waveform record(s) stored in the database. If it is contiguous, additional points up to 200ms will be retrieved for analysis.



Total Web Solutions— Providing Advanced Metering Data Integration With the Web

Total Web Solutions is an advanced Ethernet communication architecture allowing you to custom design web pages, display metering data and host your meter power information web site directly on a Nexus® meter. The Nexus® meter directly hosts the web data without any need for dedicated server software, ActiveX Controls or Java Applets. The meter does the data collection, the formatting and the page hosting. Additionally, this solution is very Information Technology Department friendly because it creates almost no network traffic and provides all formatted data through an HTTP interface without resident client software.

ADVANCED FEATURES INCLUDE:

- Fully Customizable Web Page Development
- Direct Web Page Hosting With Live Readings
- Multiple Meter Hosting On One Page
- Read Direct From Meters (No Server Software Needed)
- No Active Controls Or Java Downloads
- IT Dept Friendly. Works Through Firewalls; Low-Cost/High Functionality
- Instant Alarm Emails – Direct from the Meter

WEBEXPLORER

(Directly Host Metering Data)

EIG's WebExplorer provides you with direct access to all power data through Internet Explorer without needing to download ActiveX Controls or Java Applets. Because it is a standard HTML web page to an IT department, it works directly through corporate firewalls. WebExplorer is fully programmable so you can customize your own SCADA quality web pages, graphics and configurations.

- Easily Incorporated Into Any Existing Web Applications
- Fully Programmable Web Page Generator
- Brings in Direct XML Links, customizing many meters onto one page
- Quick Page Upload Time
- Easily Passes Through Firewalls
- No ActiveX Controls or Java Applets Downloaded to Client

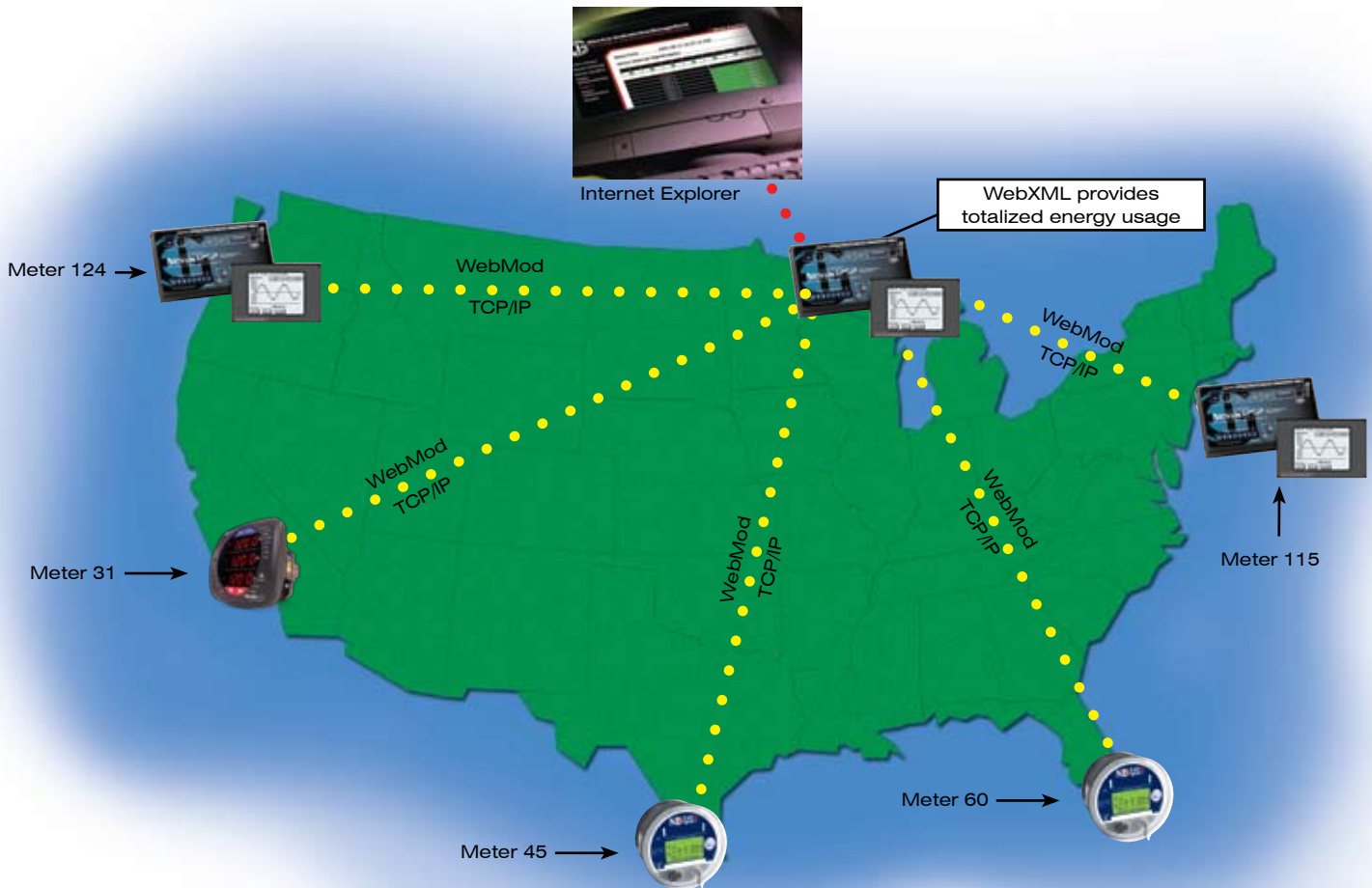

WEBXML

Creates Real Time Data in XML Format. WebXML allows the Nexus® meter to gather data from the Nexus® Host or through other meters and put the data directly into an XML format. This allows you to share data through the web to multiple applications and create custom web pages, using Web Explorer. WebXML technology is easy to configure and extremely flexible. With WebXML, your data is instantly available to a host of software applications including Internet Explorer, Excel, Power Point and Word.

- XML Support
- Automatically Process and Present Data In Readable Format
- Add Scale Factors, Multipliers or Any Other Desired HTML Capability
- Display Data from Host Meter and/or Any Other Meter Using Modbus RTU or TCP/IP (WebReacher)
- Customized Programming for Data Collection
- Easily Viewed by Different Applications
- Modbus Data Concentrator

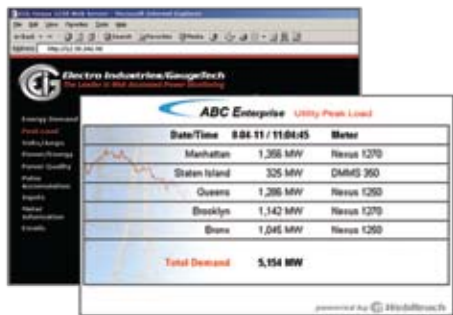

WEBREACHER

With EIG's exclusive WebReacher technology, you can now access remote meters around the world, retrieve data and consolidate it onto one web page or web site without any separate software SCADA package or client-side ActiveX Controls or Java Applets.

- No Additional Application Software Costs
- No Server System Required
- No Complex Integration
- No ActiveX Controls or Java Applets on Client
- No Costly Point Charges (Up to 32 Devices)



WEBALARM

EIG's WebAlarm sends real time email alerts via the Internet to up to 9 recipients simultaneously for any combination of event notifications. With WebAlarm, you can easily program the type of email format for the alert: either short format for cell phones with text messaging service or long format that will provide detailed alarm conditions for any devices with full email support (computers, PDAs, cell phones).

- Real Time Alerts
- Simultaneous Emails to Multiple Recipients
- Update Users on Virtually Any Abnormality
- Uses Standard SMTP – Just Assign Email Addresses
- Shows the Last 10 Emails on Web Site for Later Investigation

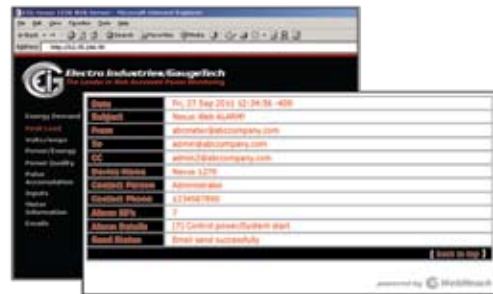

WEBMOD

(Open Architecture 3rd Party Integration)

The 10/100BaseT design allows the unit to speak with 12 simultaneous sockets of Modbus TCP. Once the card is placed inside the Nexus®, Port 2 becomes a gateway enabling other Modbus based IED equipment to be interfaced to the network LAN, thus allowing multiple requests to receive data simultaneously.

EIG's WebMod features Modbus TCP open protocol that can be easily integrated with most other software or hardware. And, with the built-in Modbus data concentrator, you can poll up to 8 devices or 512 unique polling items from any device that can speak Modbus RTU and/or Modbus TCP protocols.



WEBDNP

Using this feature, you can gain access to the meter speaking native DNP over Ethernet. This allows the unit to open an exclusive network socket for DNP 3.0. Using this unique technology, all other meter web features are available simultaneously. Even with DNP 3.0 over the Ethernet, you still have access to multiple Modbus socket, email alarms and many other communication features.

Multiple Programmable Memory Logs

Nexus® utilizes two separate logs of historical information. In addition to all power parameters, the historical logs allow users to trend data from Electro Industries' remote I/O devices. Furthermore, circuit breaker pressure, transformer temperature or any other analog or digital parameter can be monitored. You can conduct preventative maintenance on critical equipment as well as power analysis.

PRIMARY HISTORICAL TRENDING LOG FILE — LOG 1

Log any measured parameter from either the main unit or any of the option modules. Either 8, 16, 32 or 64 values can be logged per programmable interval.

SECONDARY HISTORICAL TRENDING LOG FILE — LOG 2

This log can be set up as an additional historical interval log or as an exclusive energy log. Either 8, 16, 32 or 64 values can be logged per interval.

OUT OF LIMIT LOG

The unit offers an independent out of limit log. This allows a user to download out of limit information to obtain a sequence of events for any occurrence. Utilizing the 1msec clock resolution, the logs can be combined with different metered points through a distribution system to provide an accurate system-wide depiction of a power disturbance.

Samples Per Cycle	Number of Cycles Recorded Per Screen*	Max. Number of Cycles Recorded Per Event†	Number of Channels
16	8 Pre / 56 Post Event Screen	6080	7
32	4 Pre / 28 Post Event Screen	3040	7
64	4 Pre / 12 Post Event Screen	1520	7
128	1 Pre / 7 Post Event Screen	760	7
256	1 Pre / 3 Post Event Screen	760	3
512	1 Pre / 3 Post Event Screen	760	1

* Calculations at 60Hz
† Maximum using Advanced Memory

Log Storage Options	Standard RAM	Typical Log Size	Advanced RAM	Typical Log Size
Historical Log 1	256K	85 Days	1664K	555 Days
Historical Log 2	400K	133 Days	400K	133 Days
Out of Limit	96K	1024 Events	96K	1024 Events
ITIC/CBEMA/PQ Log	64K	512 Events	64K	512 Events
Relay Output Log	48K	256 Events	48K	256 Events
Input Status Log	48K	1024 Events	48K	1024 Events
# of Waveform Events	1040K	63 Events	1568K	95 Events
Flicker Log	48K	1536 Events	160K	5120 Days
System Event Log	16K	1024 Events	16K	1024 Events
TOU Recording	128K	20 Years	128K	20 Years

Note: Historical Log 1 is calculated recording 8 values every 15 minutes. Historical Log 2 is calculated storing all integrated hour readings every 15 minutes. Every log reading is recorded with exact time stamps.

EVENT-TRIGGERED WAVEFORM RECORDING LOG

Nexus® records waveforms with a resolution of up to 512 samples per cycle. The amount of waveform recording is based on the amount of memory installed.

The unit records the waveform when a value goes out of limit and when the value returns to normal. All information is time stamped to the nearest 1msec. The 8 onboard high-speed inputs can be tied to the waveform recording. You can record when the breaker tripped as compared to when the relay activated. This is very useful for fault and breaker integrity analysis.

The unit can be programmed to take more than one recording every time an event occurs. Thousands of cycles can be recorded per event.

Nexus® stores a separate ITIC/CBEMA log that records magnitude and duration of voltage clock resolution, the logs can be combined with different metered points through a distribution system to provide an accurate system-wide depiction of a power disturbance.

RELAY OUTPUT LOG

The unit records when a relay output from the external I/O is activated, timestamps the event and provides a reason why the relay changed status.

INPUT STATUS LOG

This log is similar to the Relay Output Log in that it allows the user to record when inputs change status.

UPLOADABLE FLASH MEMORY

Nexus® utilizes uploadable flash memory technology on all processors and DSPs located in the unit. This insures that the unit can be upgraded without removing it from service.



ITIC/CBEMA LOG

Use Nexus® As an RTU

Electro Industries offers multiple Analog and Digital I/O modules that mount externally to the Nexus®. The unit supports up to 4 I/O modules using internal power. An additional power supply extends I/O capability.

The master port of the Nexus® eliminates the need for RTUs in many substation applications. The Nexus® can poll different I/O devices, log data and send data to a master station via Modbus or DNP 3.0 protocol. This I/O functionality is available in the Nexus® at much lower costs than traditional substation RTUs.

ELECTROLOGIC™ — PROGRAMMABLE LOGICAL PROTECTION AND CONTROL

The Nexus® power monitor provides advanced logic and control on programmable limit settings. The 7000 values that the monitor measures can have limits and logic set to trigger operations. This feature

allows a user to configure the Nexus® to be used as a control device for many applications such as:

- Capacitor Control
- Load Shedding
- Automatic Transfer Schemes
- Transformer Monitoring & Control
- Redundant Protection (Not designed for Primary Over-Current Protection)
- Many Other Control Functions

GRAPHICAL PROGRAMMING INTERFACE FOR RELAYING AND CONTROL

EIG's unique ElectroLogic™ structure allows users to develop up to 3 tiers of logic control based on limits and status conditions. All data is displayed in a graphical tree structure. The user can set logical descriptors, such as:

- AND/NAND/XAND Gates
- OR/ NOR/XOR Gates
- Hysteresis/NHysteresis Control

Using the graphical array, each tier configures to the desired logical scheme enabling the Nexus® to address complex control requirements. The Nexus® ElectroLogic™ control can be extended for a virtually unlimited number of relay outputs. Simply extend additional I/O modules. Response time is typically less than 200 msec per I/O module, extendible to multiple seconds.

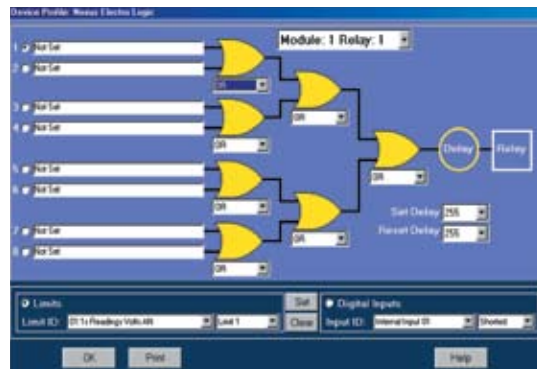

Graphical 3 Tier Programming Interface

Superior Construction and Isolation

This unit is a rugged, durable device. It provides considerable protection and isolation from damaging outside forces.

CASE CONSTRUCTION

The unit is mounted in a shielded metal case. It is resistant to contamination from harmful dust, sand or other matter. All screws and hardware are stainless steel.

POWER SUPPLY

The power supply offers both MOV protection and active line filtering to reduce any damaging occurrences to the supply.

VOLTAGE INPUTS

The voltage inputs are optically isolated. Issues such as noisy grounds, switching noise, SWC or any other such problems pose no threat to Nexus®.

CURRENT INPUTS

The current inputs are direct shorts. They offer a stud input U-Bolt design with an internal toroidal sensor. Since this is a 0.15" thick solid brass U-Bolt without solder or weld joints, the unit's current input and surge withstand capability is significant.

COMMUNICATION PORTS

All communication ports are isolated from the main unit and additionally isolated from each other. This avoids dangerous ground loops.

I/O MODULES

Each I/O module is isolated from the main unit and from other I/O modules. No signal entering an I/O module can damage any other part of the Nexus®.



Robust Communication For Every Option

4 ISOLATED HIGH-SPEED COMMUNICATION PORTS

Nexus® offers 4 built-in identical communication ports. Each port speaks any desired protocol. Standard protocols include Modbus RTU/ASCII and DNP 3.0 Level 2. Logs and Waveform events are available in Modbus format. Port 3 and Port 4 can be used as a Modbus master for I/O modules.

Additional Capabilities

8 BUILT-IN DIGITAL HIGH-SPEED STATUS INPUTS

These inputs automatically sense whether the circuit is externally wetted. If externally wetted, the input will accept up to 300VDC. If internally wetted, the unit supplies the needed voltage for the desired control application.

HIGH-SPEED TRANSDUCER OUTPUTS FOR CONTROL PURPOSES

Nexus® offers 200 msec updates for all instantaneous readings. The unit can be a high-speed control transducer for power generation, transmission line synchronization and any other synchronizing and control scheme.

SYNC. CHECK-AUX. VOLT INPUT

The unit has a high-speed Vaux input. This input can be used for multiple purposes

- Neutral to Ground
- Voltage Readings
- Synchronizing Schemes

The Vaux channel can be used to get the frequency, magnitude and phase angle on both sides of a switch or between generator and bus voltage.

INDUSTRY LEADING DNP 3.0 LEVEL 2 PLUS

The Nexus® 1252 provides the industry's most advanced DNP 3.0 protocol implementations. EIG's Nexus® 1252 complies with all DNP Level 1 and Level 2 certification requirements PLUS a host of additional features including:

- Up to 136 measurements (64 Binary Inputs, 8 Binary Counters, 64 Analog Inputs) can be mapped to DNP Static points in the customizable DNP Point map.
- Up to 16 relays and 8 resets can be controlled through DNP.
- Report-by-exception processing (DNP Events) deadbands can be set on a per-point basis.
- 250 events of combinations of four events (Binary Input Change, Frozen Counter, Counter Change, Analog Change).
- Freeze Commands: Freeze, Freeze/No-Ack, Freeze with Time, Freeze with Time/No-Ack.
- Freeze with Time command enables the Nexus® meter to have internal time driven Frozen Counter and Frozen Counter Event data. When the Nexus® meter receives the Time and Interval, the data will be created.
- Third party certification is available.

MULTIPLE COMMUNICATION PATHS

(ONE EXAMPLE SHOWN BELOW)

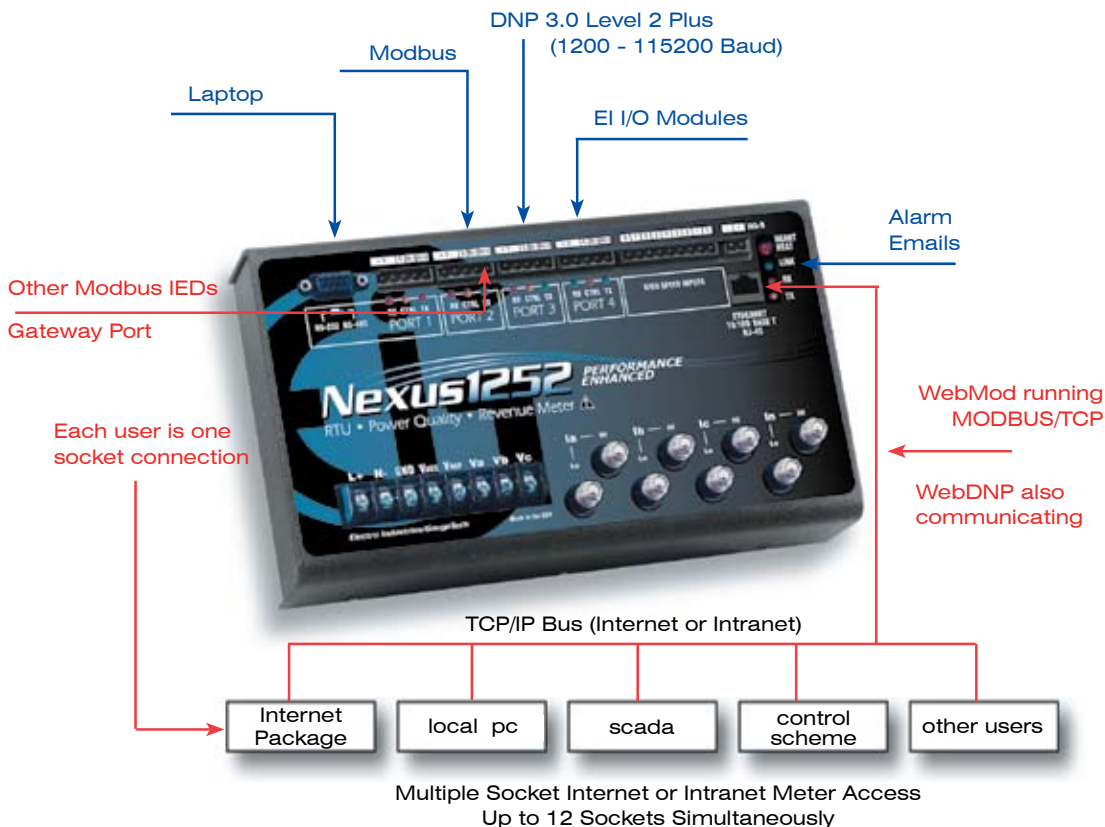

DIAL-OUT ON ALARM

With the built-in optional INP2 modem, the meter has dial-out capabilities that detect when an alarm occurs and dials out to provide notification. The Nexus® 1252 dials to EIG Dial-In Server EXT, which allows users to be paged or e-mailed with notifications of events.



Dial-Out Logic

DIAL-OUT FOR OTHER EVENTS

The meter will dial out for the following circumstances:

- Limits Status Change
- High Speed Input Change
- Waveform Record Capture
- CBEMA Power Quality Event
- Control Output Change
- Filling of Meter Memory
- Cycling of Control Power

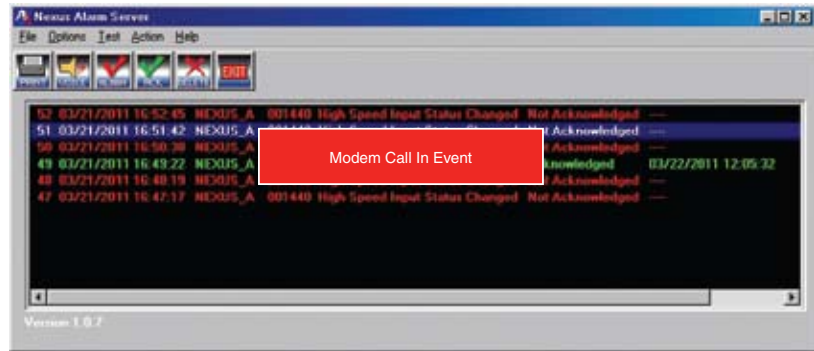

Visual Alarm Server

- Password Failure on a Call coming into the Modem
- Meter Communication Failure

DIAL-IN SERVER EXT* CAPABILITIES

The EIG Dial-In Server EXT* will record all notifications, accept downloads from the meter and allows users to be notified by email and paging automatically. Features of Dial-In Server EXT include:

- Unlimited Meters
- Scalable Multi-Server Architecture
- Email Notification
- Paging Notification
- Audible System Alarm
-

* Dial-In Server EXT is an add-on software component to Communicator EXT.

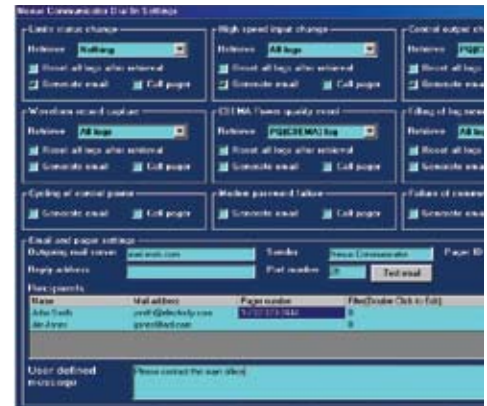

Dial-In Settings

EMAIL/PAGING FEATURE

Once the software detects a call, Communicator EXT launches the Dial-Out feature, immediately alerting those designated users via:

- Email (PC, PDA, Cell)
- Pager
- Many Users Can Be Contacted Simultaneously

Improve Reliability with Substation System Equipment Monitoring

Nexus® allows you to monitor the health and status of critical substation equipment such as transformer and circuit breakers. This insures the user that the electrical distribution infrastructure is sound and reliable.



TRANSFORMER MONITORING

- Measure Voltage, Current, Power and PF
- Limit on VA Ratings
- Data trend and /or alarm transformer temperature
- Log ambient temperature
- Monitor TAP position

CIRCUIT BREAKER MONITORING

- Record Faults
- Monitor Operations of Delays and Breakers



- Record Fault events with millisecond timing
- Count operations
- Calculate accumulated I²T on Contacts

P60N Graphical LCD Display

P60N Touch-Screen LCD for a graphical data presentation. 320 x 240 pixels, CCFL Backlight. See P60N Datasheet for details. Up to 8 Meters per display.

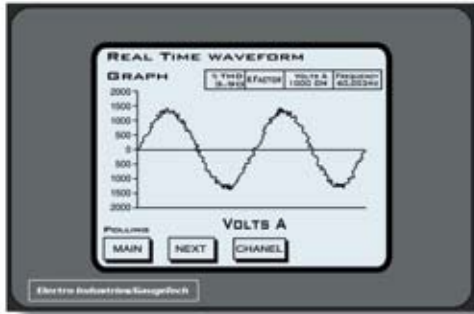

P40N+ Series Multifunction LED Displays

P40N+ Multifunction LED Display. Also used as Master Volt Display for single function remote. USB Front panel port for data downloads and real time polling.

P41N+ Amp Display Slave

P43N+ Watt/VAR/PF Display Slave



Multifunction/Master

Amps Slave

Watt/VAR/PF Slave

Analog Transducer Signal Outputs

1MAON4 4 Analog Outputs, 0–1mA, self-powered, scalable, bidirectional

1MAON8 8 Analog Outputs, 0–1mA, self-powered, scalable, bidirectional

20MAON4 4 Analog Outputs, 4–20mA, self-powered, scalable

20MAON8 8 Analog Outputs, 4–20mA, self-powered, scalable

WIRING: Common Mode

ACCURACY: 0.1% of Full Scale

CALIBRATION: Self-Calibrating

SCALING: Programmable

ORDERING SPECIFICS: Up to 4 Analog Output modules can be used with each Nexus®.

Analog Transducer Signal Inputs

8AI1 8 Analog Inputs, 0-1mA, bidirectional

8AI2 8 Analog Inputs, 0-20mA, bidirectional

8AI3 8 Analog Inputs, 0-5V DC, bidirectional

8AI4 8 Analog Inputs, 0-10V DC, bidirectional

WIRING: Common Mode

ACCURACY: 0.25% of Full Scale

SCALING: Programmable

ORDERING SPECIFICS: Up to 4 modules can be used

Digital Dry Contact Relay Outputs

4RO1 4 Relay Outputs, 5 Amps, 125V AC/DC, Form C

ORDERING SPECIFICS: Up to 4 modules can be used

Digital Solid State Pulse Outputs

4PO1 4 Solid State Pulse Outputs, Form A or C KYZ Pulses

MAXIMUM PULSE SPEED: 20 pulses per second

ORDERING SPECIFICS: Up to 4 modules can be used

Digital Inputs

8DI1 8 Digital Status Inputs Wet/Dry Auto-Detect Up to 300 Volts DC



Stackable I/O Module Design

Additional I/O Accessories

PSIO Additional power supply for up to 4 additional I/O modules. This additional accessory may be needed when using 3 or more displays and/or modules.

MBIO Mounting bracket for I/O modules

The Nexus® meter supports every wiring and configuration. It configures easily for 2, 2½ or 3 element. All wiring and hookup configurations are software configured.

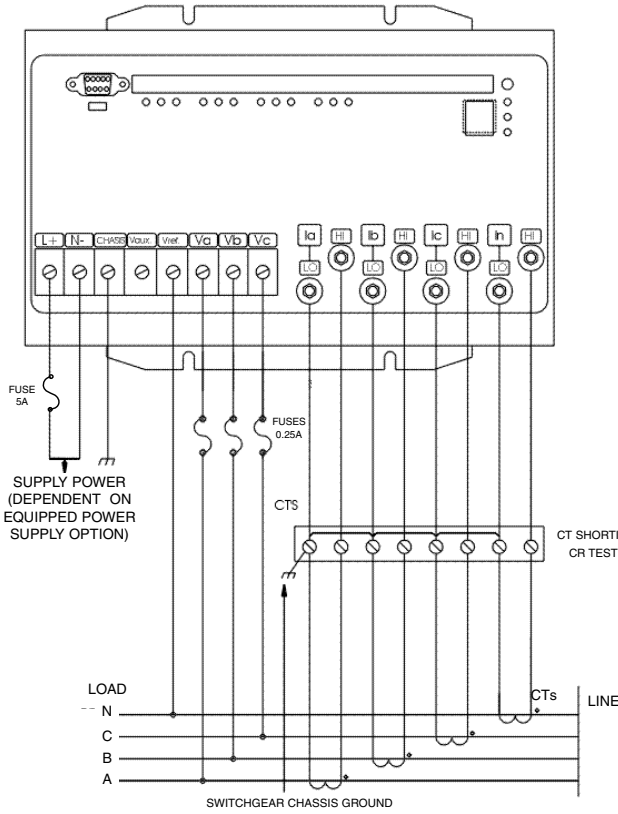

4 WIRE WYE: 3 ELEMENT DIRECT VOLTAGE

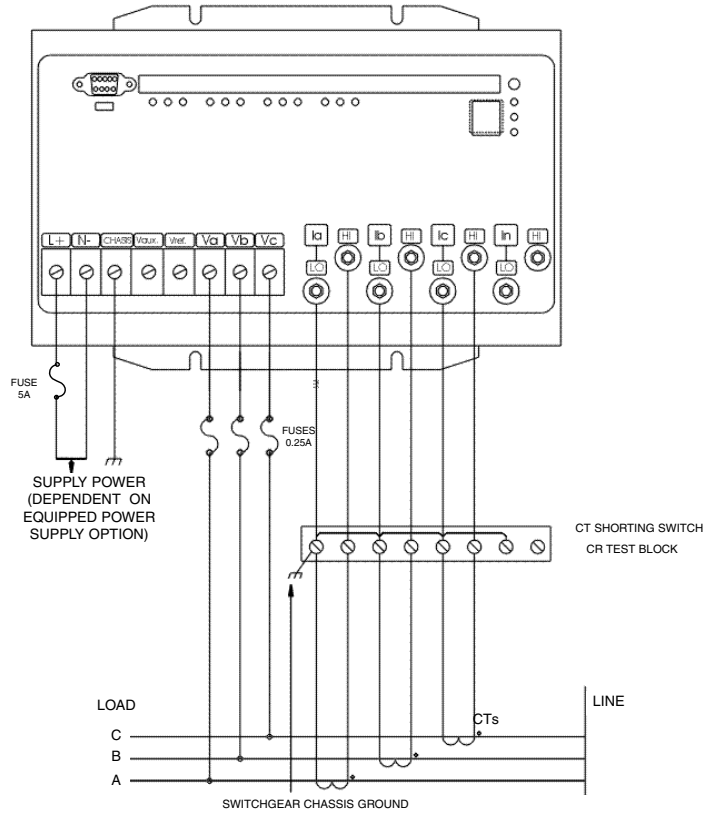

3 WIRE: 3 ELEMENT DIRECT DELTA

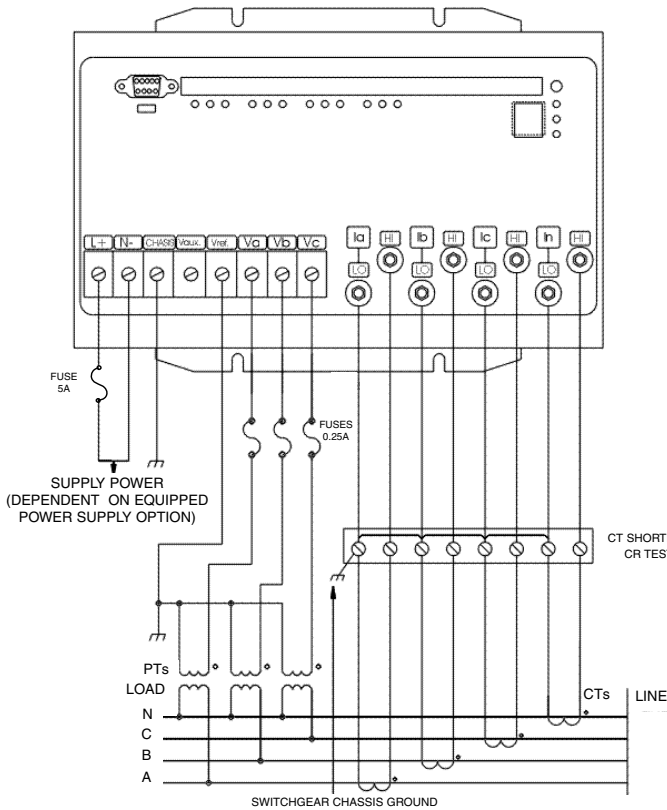

4 WIRE WYE: 3 ELEMENT CONNECTION USING 3 PTs and 4 CTs

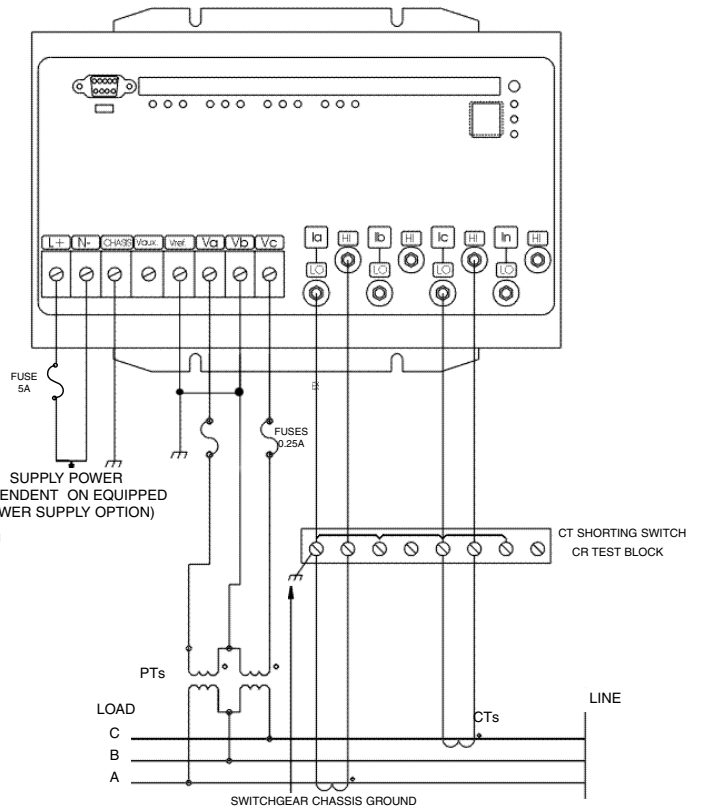

3 WIRE: 3 ELEMENT OPEN DELTA

Mounting Information

Contact Electro Industries for different mounting options.

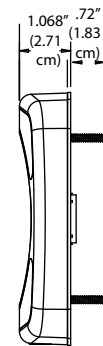
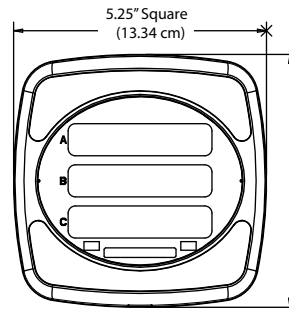
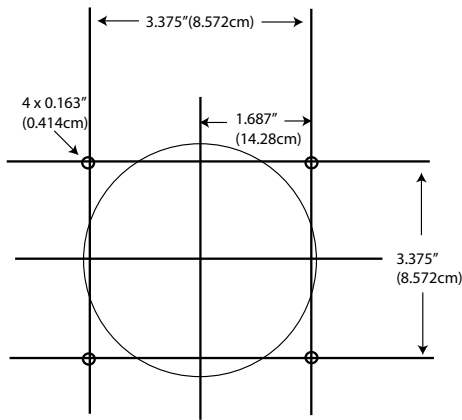
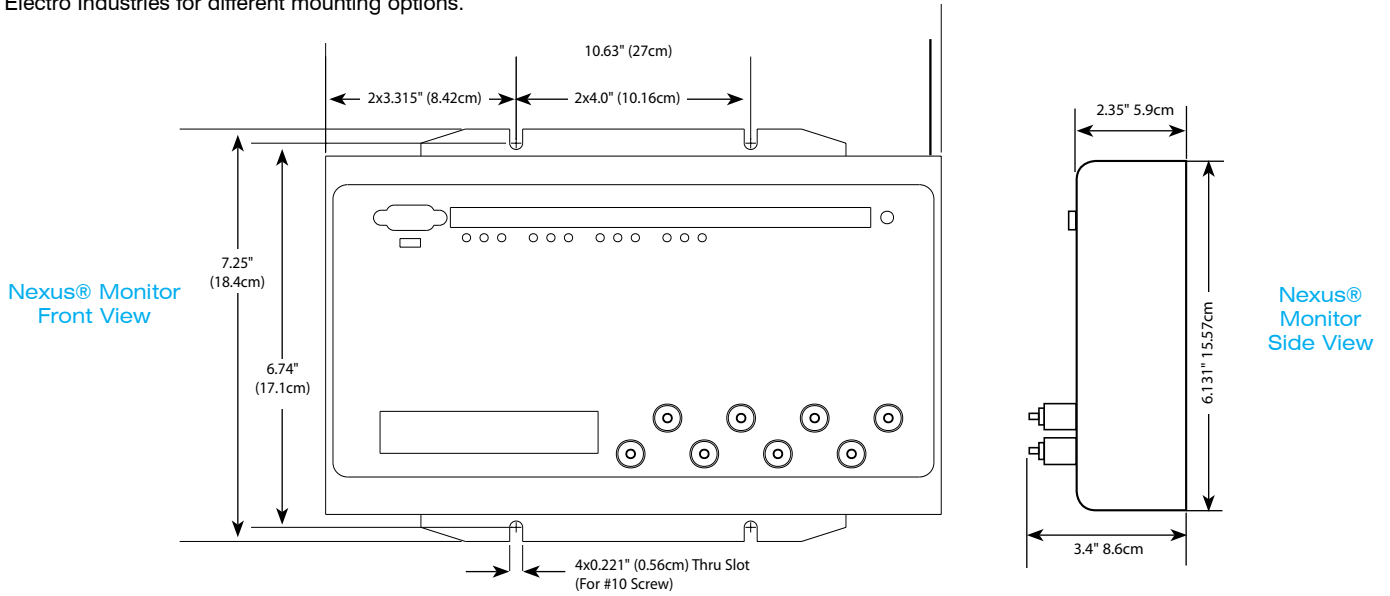

Nexus® P40N+ Display Cutout Pattern

Nexus® P40N+ Display Front View

Nexus® P40N+ Display Side View

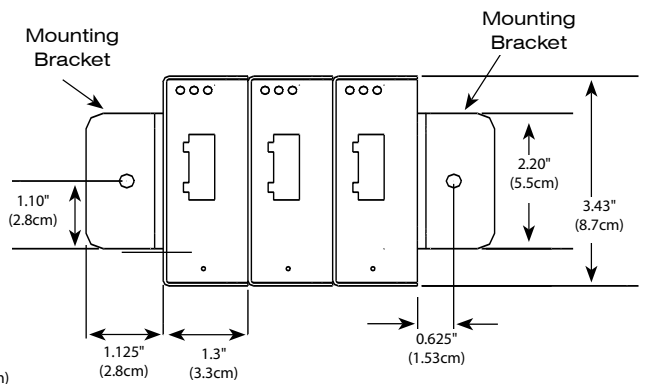
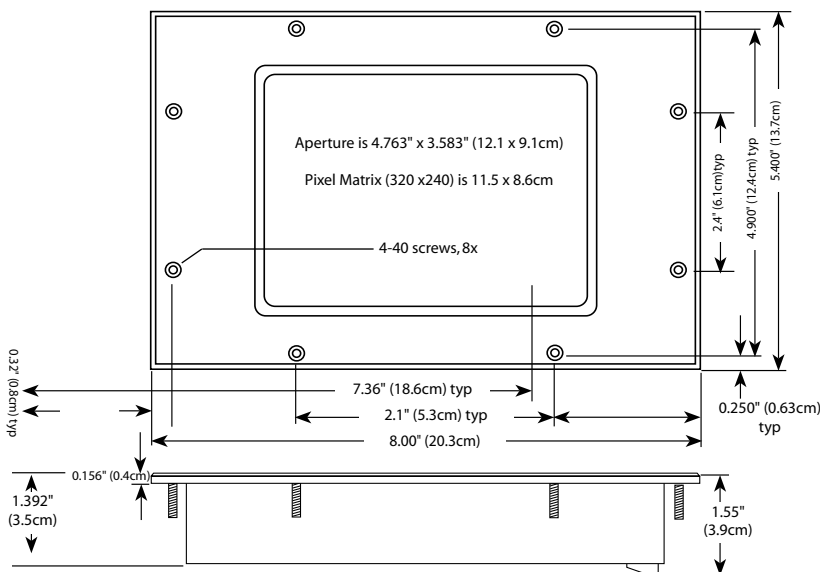

Nexus® I/O Modules Front View

Specifications

INPUT VOLTAGE RANGE

- 150 Volt PH-N, 300V PH-PH (Suffix-120)
(Used with PTs for Extended Range)
- 300 Volt PH-N, 600 Volt PH-PH (Suffix-G)
Voltage Input Withstand Capability

VOLTAGE INPUT WITHSTAND CAPABILITY

- Voltage Inputs optically isolated to 2500V DC. Meets ANSI C37.90.1 (Surge Withstand Capability)

INPUT CURRENT RANGE

- 5 Amp Inputs 2x continuous programmable to any CT range
- Fault Current recording to 60 Amps peak secondary based on 5 Amp full scale.
Note: 1 Amp and 0.25 amp current inputs available as special order.

CURRENT INPUT WITHSTAND CAPABILITY (AT 23°C)

- 100 Amps for 10 Seconds
- 300 Amps for 3 Seconds
- 500 Amps for 1 Second
- Continuous Withstand Rating: 20 Amps

BURDEN

- Voltage Inputs: 0.05VA@120V rms
- Current Inputs: 0.002VA@5A rms

ISOLATION

All inputs and outputs are isolated to 2500 Volts. All Com Ports are additionally isolated from each other.

TEMPERATURE RATING

- Operating Temperature: (-40 to +70)°C
- P60N Display 0-50 °C
- Humidity: Up to 95% Non-condensing

SENSING METHOD

- Up to 512 Samples per Cycle (Programmable)
- 16 Bit A/D Resolution – Dual Converters
- Accu-measure™ Auto-Calibration Technology
- True RMS

ACCURACY RATING

- This unit complies with ANSI C12.20 and IEC687 accuracy requirements.

UPDATE TIME

- 200 msec — High Speed Readings
- 1 Second — Revenue Accurate Reading

CONTROL POWER REQUIREMENTS

- 120V AC/DC (-20%) - 230V AC (+20%) (Suffix -D2)
- 24V DC (-20%) - 48V DC (+20%) (Suffix -D)
- Burden: 20 VA Max

FREQUENCY RANGE

- Fundamental 20– 65 Hz

COMMUNICATION FORMAT

- Programmable parity and stop bits
- Communication Protocols: Modbus TCP/IP
ASCII/RTU and DNP 3.0 Level 2 Plus
- 4 Communication ports, 2 slave ports,

2 selectable master/slave ports

- All ports use 2-wire RS485 communication; Port 1 is RS232 or RS485 Selectable
- INP2 - 56k Modem with Dial-Out Capability
- INP200 - Total Web Solutions - 10/100BaseT

CONSTRUCTION

Constructed in a metal case. All screws are stainless steel.

SHIPPING

Total shipping weight: approx. 5 lbs (2.2 kgs)

Shipping container dimensions: 14" x10" x6" (35.6cm x 25.4cm x 15.2cm)

Displays and I/O modules ship in separate containers.

COMPLIANCE

- ANSI C12.20 Class 0.2 and IEC687 (Accuracy)
- ANSI C37.90.1 (Surge Withstand)
- ANSI C62.41 (Surge)
- ANSI/IEEE C37.90.1 – Surge Withstand
- IEC 1000-4-2 – ESD
- IEC 1000-4-3 – Radiated Immunity
- IEC 1000-4-4 – Fast Transient
- IEC 1000-4-5 – Surge Immunity
- IEC 61000-4-15 – Flicker Meter
- IEC 61000-4-30 – Power Quality
- Contact factory on specifics of compliance

MEASUREMENT METHODS

- CE Marked
- UL and cUL Listed

Measurement Accuracy (% of Reading)

PARAMETER	200 MILLISECOND *	1 SECOND*	DISPLAY RESOLUTION
Voltage (L-N)	0.1%	0.05%	5 Digit
Voltage (L-L)	0.1%	0.05%	5 Digit
Current	0.1%	0.025%	5 Digit
Frequency	0.03 Hz	0.01 Hz	00.001 Hz
KW @ Unity PF	0.1%	0.06%	5 Digit
KW @ .5 PF	0.1%	0.1%	5 Digit
KVA	0.1%	0.08%	5 Digit
VAR	0.1%	0.08%	5 Digit
PF	0.1%	0.08%	3 Digit
Harmonics	N/A	0.2%	3 Digit
KW/Hours	N/A	0.04%	16 Digit
KVA/Hours	N/A	0.08%	16 Digit
KVAR/Hours	N/A	0.08	16 Digit

Note: Readings are in percent of reading where applicable (a more accurate standard), not in percent of Full Scale (a less accurate standard).

Ordering Information

To order a Nexus® 1252: Example:

1. Fill out the **options** desired on the order chart below. List accessories separately.
2. Specify display type and number.
3. Specify desired I/O modules and mounting bracket(s).
4. Specify Communicator EXT 3.0.
5. If you provide CT and PT ratios and wiring, EIG will program the units at the factory.

OPTIONS:

Nexus®1252-A-120-D2-60Hz-INP200-P40N+ - 1mAON4-8AI1-MBIO-COMEXT3.1C

ACCESSORIES:

This equates to a Nexus® 1252 Monitor with advanced memory, an operating voltage of 120, a 90-276 Volts AC/DC power supply, a 60Hz frequency, an internal 10/100BaseT Ethernet port, a multifunction LED display, a 0-1mA output module with an analog input module, mounting bracket and one site license for Communicator EXT 3.0 software.

Ordering Specifications

	Nexus® Base	Memory Options	Operation Voltages	Control Power	Frequency Range	V-Switch™ Pack	Internal Expansion Port Options	Revenue Seal
Option Numbers:								
Example:	Nexus® 1252	A	120	D	60 Hz	V1	INP200	X
	Nexus® 1252	S Standard	120 0-150 Volts PH-N 0-300 Volts PH-PH	D 18-60V DC Power Supply	60 Hz	V1 Standard Nexus®1252 Meter	X No Expansion Port	X
		A Advanced	G 300 Volts PH-N 600 Volts PH-PH	D2 90-276 Volts AC/DC Power Supply	50 Hz	V2 Advanced Flicker Measurement	INP2 56K with Dial-Out	ICR Revenue Seal
							INP200 Total Web Solutions 10/100BaseT Ethernet	

Accessory Options

DISPLAYS

- P60N** Graphical LCD Touch-Screen Display
- P40N+** Multi-Function LED Display/Master
- P41N+** Amp Display Slave
- P43N+** Watt/VAR/PF Display Slave

- PSIO** Power Supply for Additional IO modules
- MBIO** I/O Mounting Bracket (**must be ordered with purchase of I/O module**)

I/O MODULES

- 1mAON4** 4 Analog Outputs, 0-1mA
- 1mAON8** 8 Analog Outputs, 0-1mA
- 20mAON4** 4 Analog Outputs, 4-20mA
- 20mAON8** 8 Analog Outputs, 4-20mA
- 8AI1** 8 Analog Inputs, 0-1mA
- 8AI2** 8 Analog Inputs, 0-20mA
- 8AI3** 8 Analog Inputs, 0-5V DC
- 8AI4** 8 Analog Inputs, 0-10V DC
- 4RO1** 4 Relay Outputs
- 4PO1** 4 Solid State Pulse Outputs
- 8DI1** 8 Digital Status Inputs

SOFTWARE

- COMEXT3.1C** Communicator EXT 3.0 for Windows® Single-Computer License (One Site)
- COMEXT3.MC** Communicator EXT 3.0 for Windows® Multiple-Computer License (One Site)
- AIEXT.1C** AiReports EXT Power Analysis Software for Windows® Single-Computer License (One Site)
- AIEXT.MC** Multiple-Computer License (One Site)
- DISEXT.1C** Dial-In Server EXT For Modems Single-Computer License (One Site)
- DISEXT.MC** Dial-In Server EXT For Modems Multi-Computer License (One Site)

1800 Shames Drive • Westbury, NY 11590

1-877-EIMETER (1-877-346-3837)

Tel: 516-334-0870 • **Fax:** 516-338-4741

Email: sales@electroind.com

Web Site: www.electroind.com



Electro Industries/GaugeTech
The Leader in Power Monitoring and Smart Grid Solutions