

Quick Start Guide for the Shark® 100S/200S Submeters

Mechanical Installation

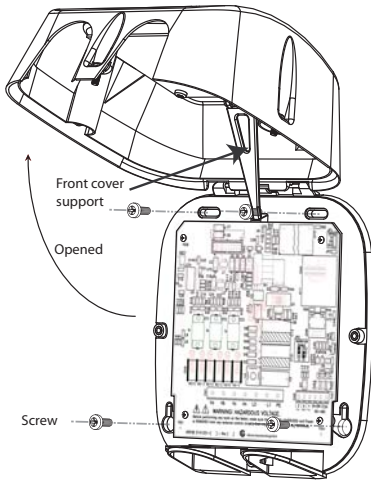

Shark® Submeter Opened - All wiring is done with the cover as shown. The front cover support fits into its base. **Do not** rest the support on the board assembly, and make sure the support is up before closing the front cover.

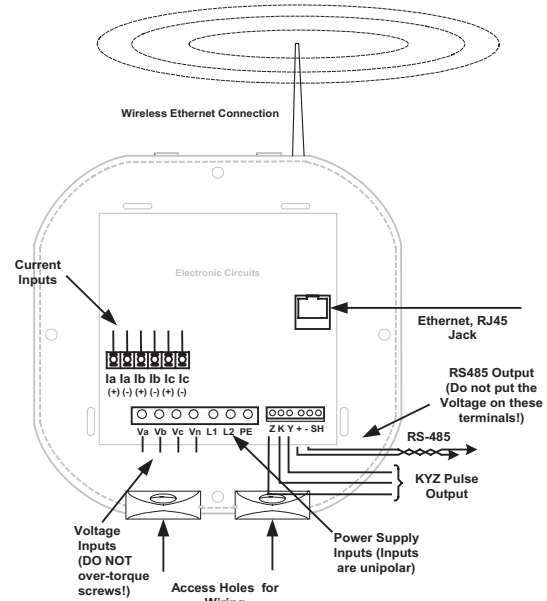

Communication Connections - RS485, Ethernet and KYZ Pulse
(Do not put Voltage on communication terminals!)

Electrical Installation

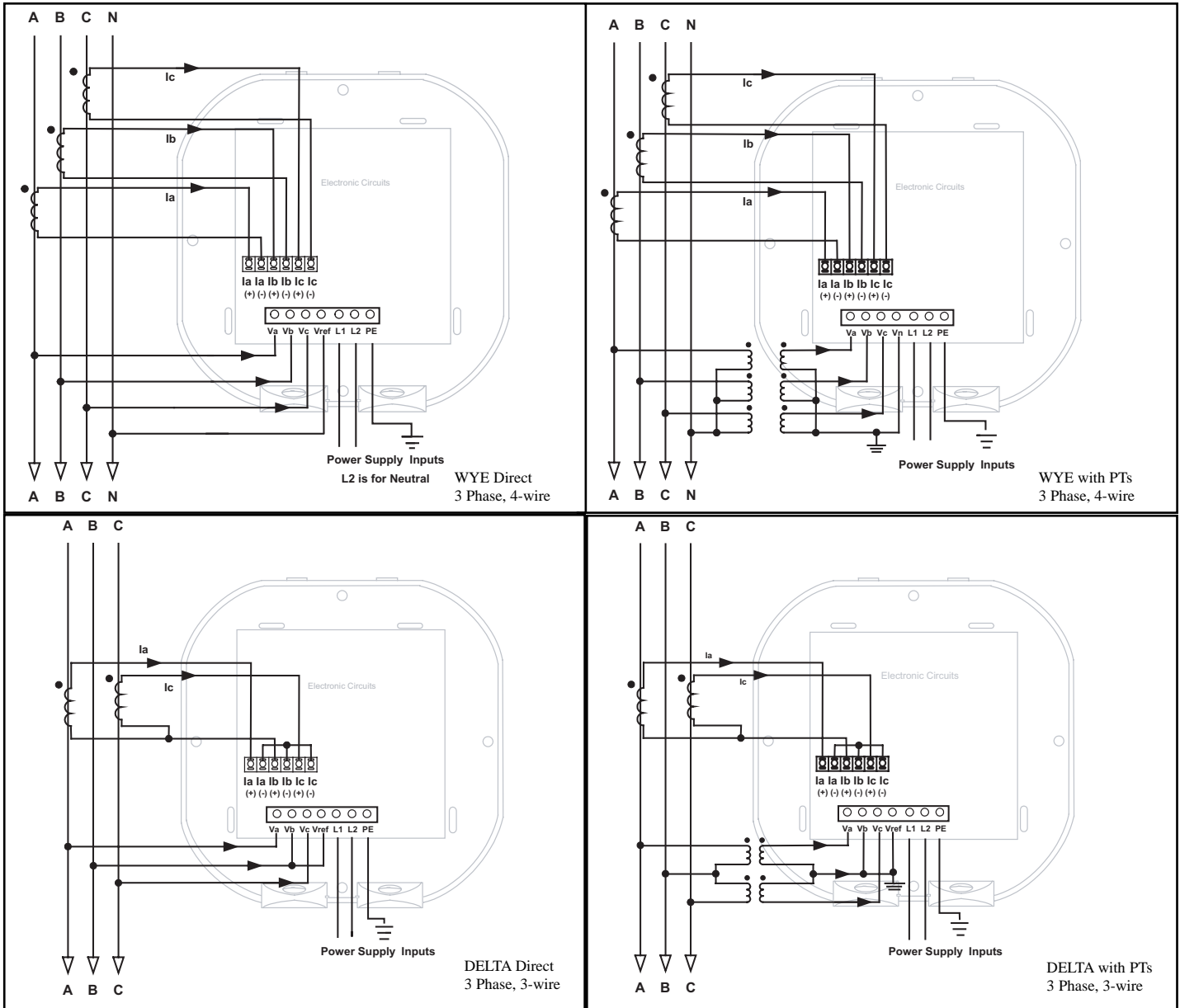

Program Settings Using the Meter's Faceplate Buttons (Cover Closed)

■ Configuration Mode Using Buttons: MENU, ENTER, DOWN (Arrow) and RIGHT (Arrow)

Push MENU from any Readings screen. The MAIN MENU screens appear. Push DOWN and the Configuration Mode String (CFG) blinks in A Screen. Push ENTER. The Configuration Mode Scroll, CT, PT screen appears. Push DOWN to scroll to CT, PT, Cnct.

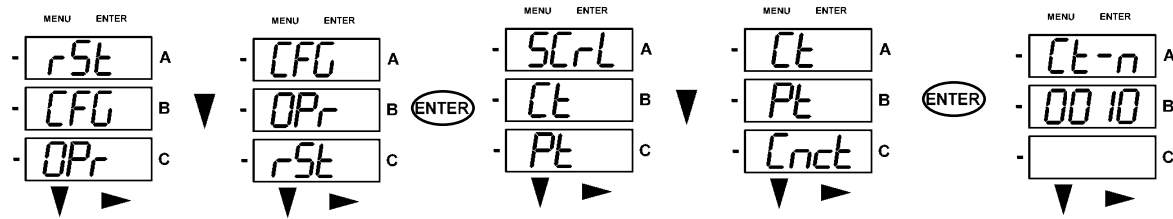

■ Enter Password

All parameters in Configuration Mode (except Scroll) require a 4-digit PASSWORD to change a setting.

On the CT, PT, Cnct screen., push ENTER. The Ct-n screen appears. Push DOWN and the Password screen appears.

Four dashes appear in the B Screen. The left digit flashes. Use the DOWN button to change the digit.

Use the RIGHT button to move to the next digit. Push ENTER.

If the correct Password was entered, you return to the Ct-n and the left digit of the setting flashes (ready for change).

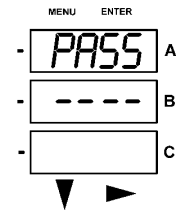

■ Configure CTs (Example Screens) and PTs

There are 3 CT Screens: Ct-n (Numerator), Ct-d (Denominator) and Ct-S (Scaling). PT Screens are similar.

Push DOWN to scroll from 0 to 9 to enter a new digit. Push RIGHT to move to the next digit. When the new setting is entered, push ENTER. The Ct-d screen is PRESET at the factory and cannot be changed. Push ENTER, repeat steps for Ct-S. Push ENTER. PT Configuration Screens will appear next, then Connection (Cnct) screens

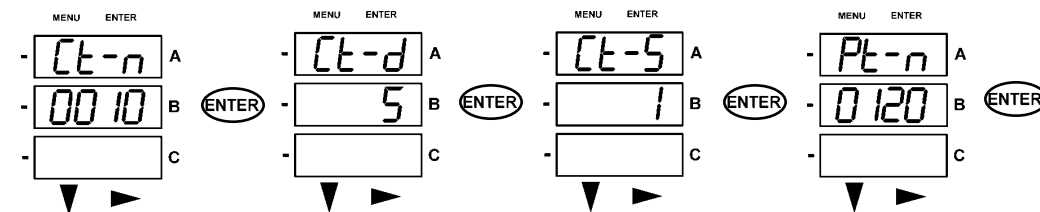

* PRESET to 5 or 1 Amp Value

■ Wiring Connection (Cnct)

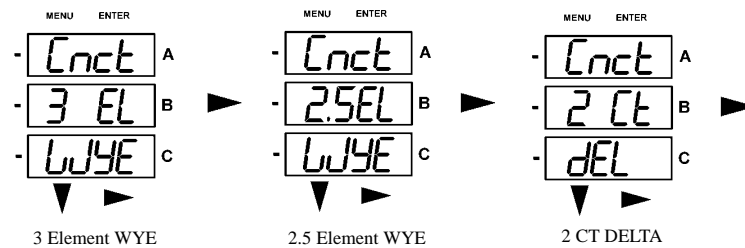

Use RIGHT to scroll settings. Push MENU twice. Stor ALL? YES appears. To store all settings, push ENTER. Stor ALL DONE appears.

Or, if you do not want to store the new settings, push RIGHT to Stor ALL? no. Push ENTER and return to Auto-Scroll Parameter Designators.

Example CT Settings:

200/5 Amps:
800/5 Amps:
2,000/5 Amps:
10,000/5 Amps:

Set the Ct-n value for 200, Ct-S value for 1.
Set the Ct-n value for 800, Ct-S value for 1.
Set the Ct-n value for 2000, Ct-S value for 1.
Set the Ct-n value for 1000, Ct-S value for 10.

Example PT Settings:

14,400/120 Volts:
138,000/69 Volts:
345,000/115 Volts:
345,000/69 Volts

Pt-n value is 1440, Pt-d value is 120, Pt-S value is 10.
Pt-n value is 1380, Pt-d value is 69, Pt-S value is 100.
Pt-n value is 3450, Pt-d value is 115, Pt-S value is 100.
Pt-n value is 345, Pt-d value is 69, Pt-S value is 1000.

NOTE: For other wiring configurations and further details, refer to the Shark® 100S or 200S User's Manual & Communicator EXT 3.0 Software Manual on the enclosed CD.

