

Quick Start Guide for SHARK Series Meters

Mechanical Installation

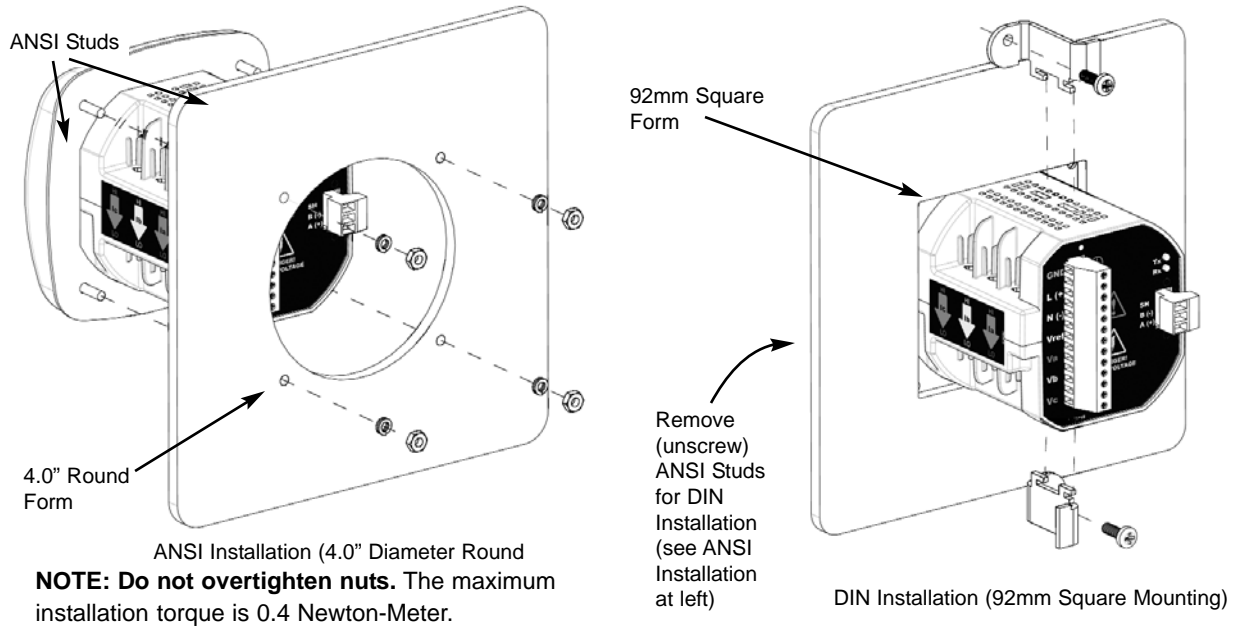

Electrical Wiring

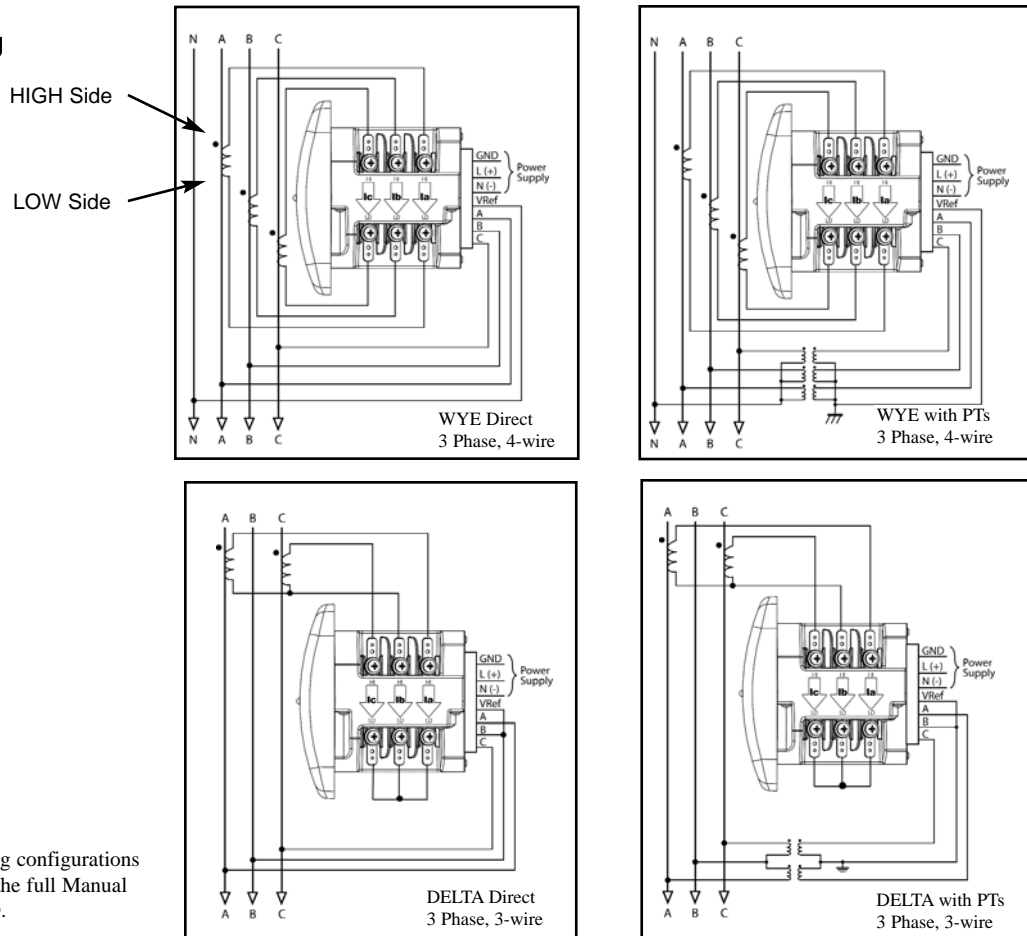

Program Settings Using the Shark Faceplate Buttons

■ Configuration Mode Using Buttons: MENU, ENTER, DOWN (Arrow) and RIGHT (Arrow)

Push MENU from any Readings screen. The MAIN MENU screens appear. Push DOWN and the Configuration Mode String (CFG) blinks in A Screen. Push ENTER. The Configuration Mode Scroll, CT, PT screen appears. Push DOWN to scroll to CT, PT, Cnct.

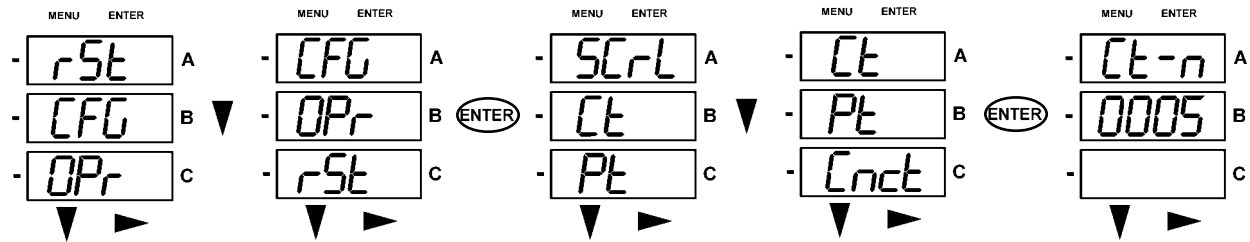

■ Enter Password

All parameters in Configuration Mode (except Scroll) require a 4-digit PASSWORD to change a setting.

On the CT, PT, Cnct screen., push ENTER. The Ct-n screen appears. Push DOWN and the Password screen appears.

Four dashes appear in the B Screen. The left digit flashes. Use the DOWN button to change the digit.

Use the RIGHT button the move to the next digit. Push ENTER.

If the correct Password was entered, you return to the Ct-n and the left digit of the setting flashes (ready for change).

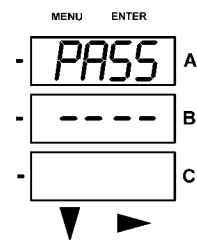

■ Configure CTs (Example Screens) and PTs

There are 3 CT Screens: Ct-n (Numerator), Ct-d (Denominator) and Ct-S (Scaling). PT Screens are similar.

Push DOWN to scroll from 0 to 9 to enter a new digit. Push RIGHT to move to the next digit. When the new setting is entered, push ENTER. The Ct-d screen is PRESET at the factory and cannot be changed. Push ENTER, repeat steps for Ct-S. Push ENTER. PT Configuration Screens will appear next, then Connection (Cnct) screens.

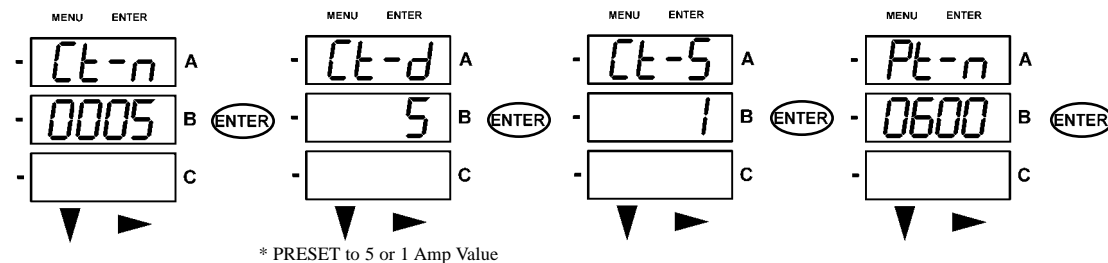

■ Wiring Connection (Cnct)

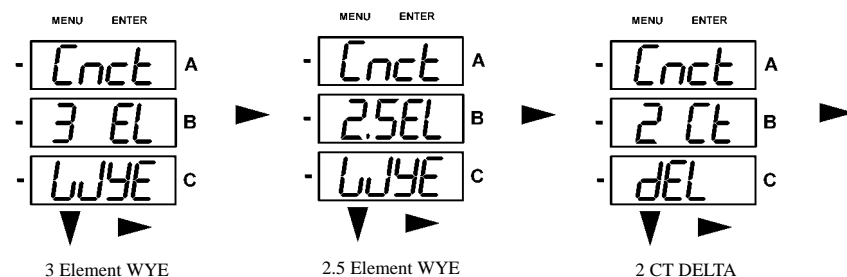

Use RIGHT to scroll settings. Push MENU twice and Stor ALL? YES appears. To store all settings, push ENTER. Stor ALL DONE appears.

Or, if you do not want to store the new settings, push RIGHT to Stor ALL? no. Push ENTER and return to Auto-Scroll Parameter Designators.

Example CT Settings:

200/5 Amps:
800/5 Amps:
2,000/5 Amps:
10,000/5 Amps:

Set the Ct-n value for 200, Ct-S value for 1.
Set the Ct-n value for 800, Ct-S value for 1.
Set the Ct-n value for 2000, Ct-S value for 1.
Set the Ct-n value for 1000, Ct-S value for 10.

Example PT Settings:

14,400/120 Volts:
138,000/69 Volts:
345,000/115 Volts:
345,000/69 Volts

Pt-n value is 1440, Pt-d value is 120, Pt-S value is 10.
Pt-n value is 1380, Pt-d value is 69, Pt-S value is 100.
Pt-n value is 3450, Pt-d value is 115, Pt-S value is 100.
Pt-n value is 345, Pt-d value is 69, Pt-S value is 1000.

NOTE: For further details, refer to the Shark User's Manual & Communicator EXT 3.0 Software Manual on the enclosed CD.