

**How to configure an M-7679R-PAC with an M-2406 Adapter Chassis to  
Retrofit an EATON Cooper Form 6 (ECF6) Control**

Rev 4/12/19

**Document Tags:** M-7679, M-2406, A-2406, Form 6

# M-2406 Recloser Control Adapter Chassis

**Adapts M-7679 R-PAC to Retrofit Eaton Cooper  
Form 6 Controls for Use With 14 or 19-Pin  
Eaton Cooper Nova Reclosers**



The purpose of this document is to identify the information required to properly configure an M-7679 R-PAC and an M-2406 Adapter Chassis to retrofit an EATON Cooper Form 6 Control for a NOVA 14 or 19-Pin Reclosers



## Compatibility with 19-Pin NOVA VTC Ready Reclosers

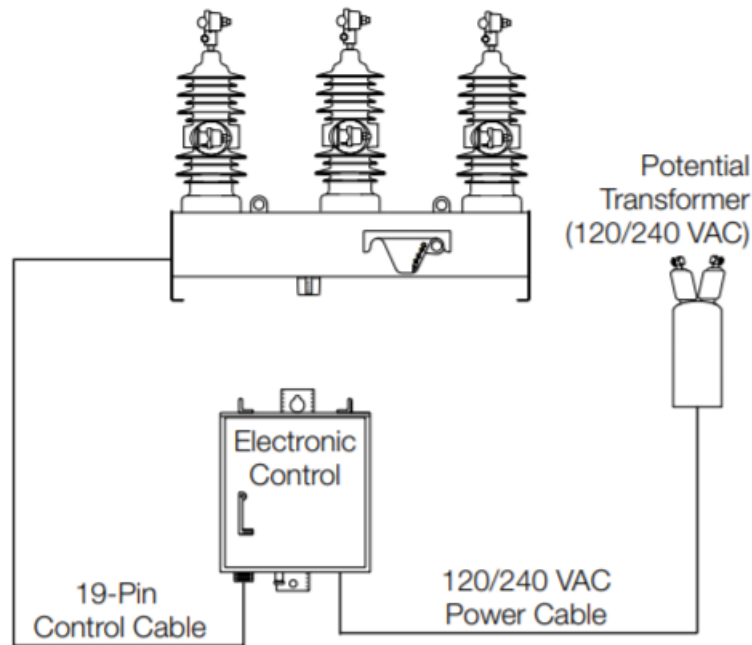
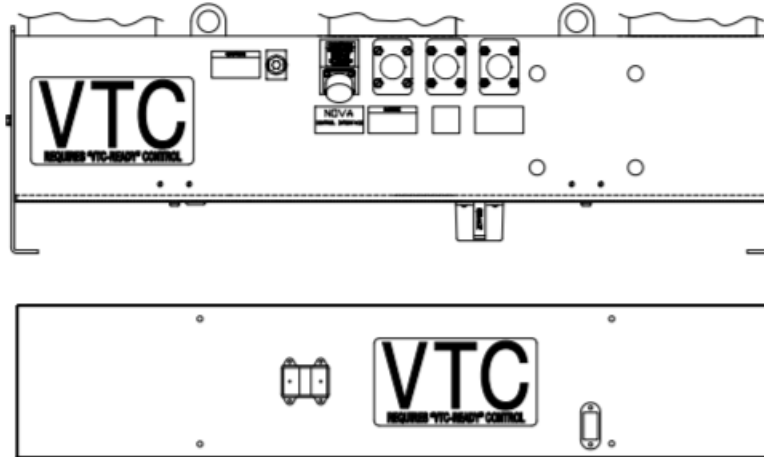

**Figure 2. Control-powered NOVA recloser configuration with potential transformer input power.**

The M-2406 is compatible with existing 19-Pin recloser control cabinets used with Control-powered NOVA VTC Ready reclosers manufactured after September 2004. These systems use a Voltage Trip/Close (VTC) interface and a VTC-ready control for tripping and closing. These systems can be easily identified in several ways:

1. The NOVA Recloser will have a big blue label indicating that the recloser requires a VTC-Ready control





**Figure 7. Control-powered NOVA recloser VTC labels.**

2. By the serial number of the recloser (see recloser nameplate). VTC Nova Reclosers have serial numbers 100,000 and above or beginning with the characters CP57

**Table 6. Serial Number Break for Control-Powered NOVA Reclosers with VTC**

<b>Control-Powered NOVA Recloser</b>	<b>Serial No.</b>
NOVA 15	100,000 or CP57#####
NOVA 27	100,000 or CP57#####
NOVA 38	100,000 or CP57#####

3. Verifying the back of the existing Cooper Form 6 control that it has the P1, P3 and P4 connectors

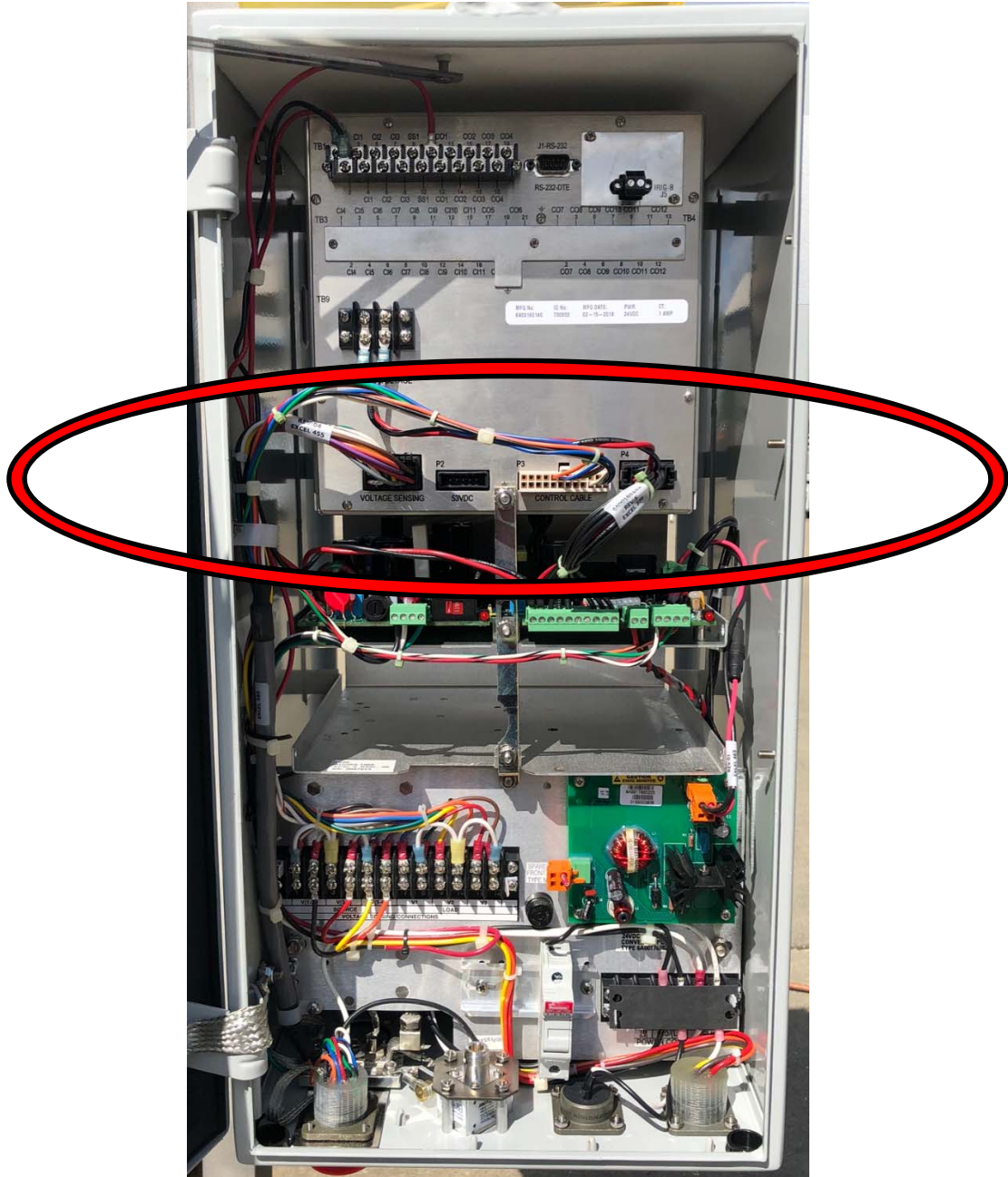

## Compatibility with 14-Pin Nova Auxiliary-Powered Reclosers

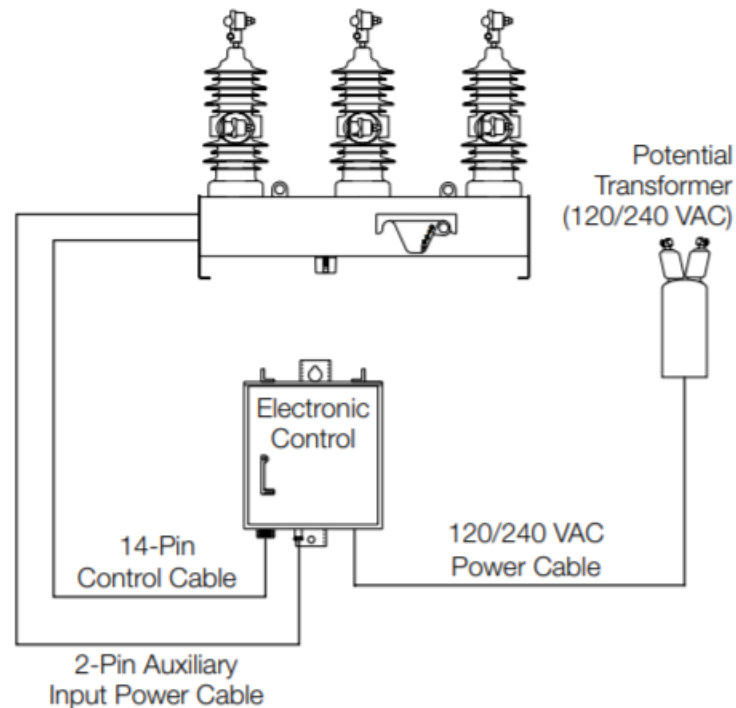

**Figure 4. Auxiliary-powered NOVA recloser mechanism configuration with potential transformer input power.**

The M-2406 is compatible with existing 14-Pin recloser control cabinets used with Auxiliary-powered Nova recloser mechanisms. These systems use an auxiliary AC or DC voltage input of 120Vac/240Vac, 125Vdc, or 250Vdc. The auxiliary input power supply (AC or DC) is connected to a 2-pin male receptacle located next to the 14-pin female control receptacle. This provides power to the trip-and-close capacitors and the heaters in the recloser.

Compatibility with the 2406 Adapter Chassis can be verified by looking at the back of the existing Cooper Form 6 control to validate that it has the P1, P3 and P4 connectors.

## M-7679 R-PAC

Proper configuration of the M-7679 R-PAC is required to complete a retrofit particularly if the NOVA Recloser offers the optional voltage sensing inputs. The following options are typical for a Cooper Form 6 retrofit using the Beckwith M-2406 Adapter Chassis; the options highlighted in yellow require confirmation from the end user. The information about the quantity and type of voltage sensors (IVS or PT) can be found in the nameplate of the NOVA Recloser:

M-7679- V6L1MX6ELV2C0000		
IED MOUNTING	V	Vertical
OPERATING FREQUENCY	6	60 Hz
IED POWER SUPPLY	L	Low Voltage Range 18-60 Vdc
PHASE CURRENT INPUTS	1	1 Amp
GROUND CURRENT INPUT	M	50 mA SEF
VOLTAGE INPUTS	X6	(3) 12 Vac Max, (3) 300 Vac Max
I/O OPTIONS	EL	(12) 9-60 Vdc IN, (12) 8 A OUT
OPERATION TYPE	V	Distribution Automation Package Three Phase Ganged
PORT 1 (SERIAL)	2	TIA-232
PORT 2, PORT 3 (ETHERNET)	CO	RJ-45 10/100 Mbps, None
PORT 4 (SERIAL)	0	None
PROTOCOLS	0	DNP 3.0 & MODBUS
IED CUSTOMER REQUIREMENTS	0	None

This is the complete Style Selection Table for the M-7679 R-PAC

M-7679 R-PAC Style Selection Table		
M-7679 - V6L1MH4SLA200000		
S Vertical	V	Mounting
S Horizontal	H	
S 60Hz	6	Frequency
S 50Hz	5	
S Low (18-60 Vdc)	L	Power Supply
S High (90-315 Vac/Vdc)	H	
S 1 A (3)	1	Phase Current Inputs (1, 12, 13)
S 5 A (3)	5	
S 1 A	1	
S 5 A	5	Ground Current Input (Ig)
S 200 mA SEF	H	
S 50 mA SEF	M	
S 10 mA SEF	L	
S (4) LEA-High or VT (300 Vac Max)	H4	Voltage Inputs
S (4) LEA-Low (12 Vac Max)	L4	
S (3) LEA-Low (12 Vac Max) and (1) LEA-High or VT (300 Vac Max)	X4	
S (6) LEA-High or VT (300 Vac Max)	H6	
S (6) LEA-Low (12 Vac Max)	L6	
S (3) LEA-Low (12 Vac Max) and (3) LEA-High or VT (300 Vac Max)	X6	
S (4) Configurable LV Inputs 9-60 Vdc, and (4) Configurable Dry Type Outputs	SL	I/O Options
S (4) Configurable HV Inputs 90-300 Vdc, and (4) Configurable Dry Type Outputs	SH	
S (8) Additional LV Inputs 9-60 Vdc, and (8) Additional Dry Type Outputs	EL	
S (8) Additional HV Inputs 90-300 Vdc, and (8) Additional Dry Type Outputs	EH	
CSR	0 None	
	X Customer Specific Requirements	◆
Protocols	0 Standard (DNP3.0 & MODBUS)	S
	4 IEC 60870-5-104	\$
	6 IEC 61850 (Requires an Ethernet port)	\$
PORT 4 (Serial)	0 None	S
	2 TIA-232 Port	\$
	4 TIA-485 Port	\$
	S Serial Fiber Optic ST Port	\$
	V Serial Fiber Optic V-pin Port	\$
PORT 2/ PORT 3 (Ethernet)	00 None (none/none)	S
	CO 1 x RJ-45 10/100 Mbps Ethernet Port (RJ-45/none)	\$
	FO 1 x ST Fiber Optic Port 100 Base-FX (FO/none)	\$
	CC 2 x RJ-45 10/100Mbps Ethernet Port (RJ-45/RJ-45)	\$
	CF 1 x RJ-45 10/100Mbps Ethernet Port + 1 x ST Fiber Optic Port 100 Base-FX (RJ-45/FO)	\$
	FF 2 x ST Fiber Optic Port 100 Base-FX (FO/FO)	\$
PORT 1 (Serial)	2 TIA-232 Port	S
	4 TIA-485 Port	S
	S Serial Fiber Optic ST Port	\$
	V Serial Fiber Optic V-pin Port	\$
Operation Type	S Switch/Sectionalizer (SW/SECT) – Three-Phase Ganged	S
	A Recloser – Three Phase Ganged	S
	T Recloser – Independent Phase Capable (Requires expanded I/O option)	\$
	V Distribution Automation Package (79, SW/SECT, LS, ATS) – Three-Phase Ganged	\$
	W Distribution Automation Package (79, SW/SECT, LS, ATS) – Independent Phase Capable (Requires expanded I/O option)	▲ \$

S = Standard  
 \$ = Optional With Price Adder  
 ◆ = Consult Factory

**CUSTOMER QUESTIONS TO CONFIGURE AN M-7679 R-PAC TO BE USED WITH AN M-2406 TO RETROFIT AN EATON COOPER FORM 6 CONTROL**

QUESTION ABOUT APPLICATION	M-7679 R-PAC
1. <b>SENSING VOLTAGE?</b> - Does your 14 or 19-Pin EATON Cooper NOVA recloser has the optional Voltage inputs? If Not then skip to question 3 if yes then continue.	Yes or No
2. <b>HOW MANY VOLTAGES AND TYPE?</b> - What type of voltage sensing is provided from your NOVA recloser? a. From the SOURCE side i. None ii. 3 x Standard PT (120Vac nominal) iii. 3 x IVS Sensors (4 Vac nom, 12 Vac Max)	None, 3 or 6 (see 2a and 2b)
b. From the LOAD side i. None	M-7679 Voltage Option <b>H4</b> (if 2ai is selected)
ii. 3 x Standard PT (120Vac nominal)	<b>H6</b> (if 2aii is selected) or <b>X6</b> (if 2aiii is selected)
iii. 3x IVS Sensors (4 Vac nom, 12 Vac Max)	<b>Select Voltage Option X6</b> (if 2aii is selected) or <b>L6</b> (if 2aiii is selected)
3. <b>OPERATION TYPE?</b> – What application are you using your NOVA recloser for? a. Just as a Recloser (79)? b. As a recloser or sectionalizer or in a loop scheme?	Operation Type <b>A</b> Operation Type <b>V</b>
4. <b>COMMUNICATION PORTS</b> – The M-7679 comes standard with USB, SD Port and 1 x RS-232. Do you need any additional serial ports (232 or 485) and/or Ethernet Ports (RJ45 or Fiber)?	Select proper communication ports from Style Selection Table
5. <b>OPTIONAL COMMUNICATION PROTOCOLS</b> – The M-7679 comes standard with DNP and MODBUS. Do you need any other protocol like IEC61850?	Select proper communication protocols from Style Selection Table

**M-7679 R-PAC Style Selection Table**

**M-7679 - V 6 L 1 M H 4 S L A 2 0 0 0 0 0**

<input type="checkbox"/> S Vertical	V	Mounting	<input type="checkbox"/> CSR 0 None	<input type="checkbox"/> S
<input type="checkbox"/> S Horizontal	H		<input checked="" type="checkbox"/> X Customer Specific Requirements	<input type="checkbox"/> ▲
<input type="checkbox"/> S 60Hz	6	Frequency	<input type="checkbox"/> 0 Standard (DNP3.0 & MODBUS)	<input type="checkbox"/> S
<input type="checkbox"/> S 50Hz	5		<input type="checkbox"/> 4 IEC 60870-5-104	<input type="checkbox"/> S
<input type="checkbox"/> S Low (18-60 Vdc)	L	Power Supply	<input type="checkbox"/> 6 IEC 61850 (Requires an Ethernet port)	<input type="checkbox"/> S
<input type="checkbox"/> S High (90-315 Vac/Vdc)	H		<input type="checkbox"/> 0 None	<input type="checkbox"/> S
<input type="checkbox"/> S 1 A (3)	1	Phase Current Inputs (I1, I2, I3)	<input type="checkbox"/> 2 TIA-232 Port	<input type="checkbox"/> S
<input type="checkbox"/> S 5 A (3)	5		<input type="checkbox"/> 4 TIA-485 Port	<input type="checkbox"/> S
<input type="checkbox"/> S 1 A	1	Ground Current Input (Ig)	<input type="checkbox"/> S Serial Fiber Optic ST Port	<input type="checkbox"/> S
<input type="checkbox"/> S 5 A	5		<input type="checkbox"/> V Serial Fiber Optic V-pin Port	<input type="checkbox"/> S
<input type="checkbox"/> S 200 mA SEF	H		<input type="checkbox"/> 00 None (none/none)	<input type="checkbox"/> S
<input type="checkbox"/> S 50 mA SEF	M		<input type="checkbox"/> CO 1 x RJ-45 10/100 Mbps Ethernet Port (RJ-45/none)	<input type="checkbox"/> S
<input type="checkbox"/> S 10 mA SEF	L		<input type="checkbox"/> FO 1 x ST Fiber Optic Port 100 Base-FX (FO/none)	<input type="checkbox"/> S
<input type="checkbox"/> S (4) LEA-High or VT (300 Vac Max)	H4	Voltage Inputs	<input type="checkbox"/> CC 2 x RJ-45 10/100Mbps Ethernet Port (RJ-45/RJ-45)	<input type="checkbox"/> S
<input type="checkbox"/> S (4) LEA-Low (12 Vac Max)	L4		<input type="checkbox"/> CF 1 x RJ-45 10/100Mbps Ethernet Port + 1 x ST Fiber Optic Port 100 Base-FX (RJ-45/FO)	<input type="checkbox"/> S
<input type="checkbox"/> S (3) LEA-Low (12 Vac Max) and (1) LEA-High or VT (300 Vac Max)	X4		<input type="checkbox"/> FF 2 x ST Fiber Optic Port 100 Base-FX (FO/FO)	<input type="checkbox"/> S
<input type="checkbox"/> S (6) LEA-High or VT (300 Vac Max)	H6		<input type="checkbox"/> 2 TIA-232 Port	<input type="checkbox"/> S
<input type="checkbox"/> S (6) LEA-Low (12 Vac Max)	L6		<input type="checkbox"/> 4 TIA-485 Port	<input type="checkbox"/> S
<input type="checkbox"/> S (3) LEA-Low (12 Vac Max) and (3) LEA-High or VT (300 Vac Max)	X6		<input type="checkbox"/> S Serial Fiber Optic ST Port	<input type="checkbox"/> S
<input type="checkbox"/> S (4) Configurable LV Inputs 9-60 Vdc, and (4) Configurable Dry Type Outputs	SL	I/O Options	<input type="checkbox"/> V Serial Fiber Optic V-pin Port	<input type="checkbox"/> S
<input type="checkbox"/> S (4) Configurable HV Inputs 90-300 Vdc, and (4) Configurable Dry Type Outputs	SH		<input type="checkbox"/> S Switch/Sectionalizer (SW/SECT) – Three-Phase Ganged	<input type="checkbox"/> S
<input type="checkbox"/> S (8) Additional LV Inputs 9-60 Vdc, and (8) Additional Dry Type Outputs	EL		<input type="checkbox"/> A Recloser – Three Phase Ganged	<input type="checkbox"/> S
<input type="checkbox"/> S (8) Additional HV Inputs 90-300 Vdc, and (8) Additional Dry Type Outputs	EH		<input type="checkbox"/> T Recloser – Independent Phase Capable (Requires expanded I/O option)	<input type="checkbox"/> S
			<input type="checkbox"/> V Distribution Automation Package (79, SW/SECT, LS, ATS) – Three-Phase Ganged	<input type="checkbox"/> S
			<input type="checkbox"/> W Distribution Automation Package (79, SW/SECT, LS, ATS) – Independent Phase Capable (Requires expanded I/O option)	<input type="checkbox"/> S

S = Standard  
\$ = Optional With Price Adder  
◆ = Consult Factory